



شركة المطور المعتمد للمقاولات

Al-motawer Al-moutamed Cons Co

CCD



المطور المعتمد
للمقاولات

من نحن

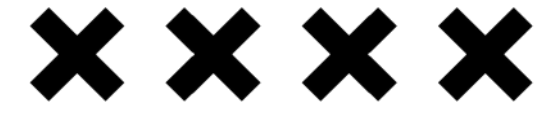

☀ قصة النجاح المتكاملة
التاريخ والتأسيس

(CCD) تأسست شركة المطور المعتمد للمقاولات
عام 2020 برؤية واضحة لتكون ركيزة أساسية في قطاع المقاولات
السعودي وتعمل بفضل الله في عدة مجالات منها المقاولات والتطوير
العقاري والتوريدات والتشغيل والصيانة والصناعات الأسمنتية

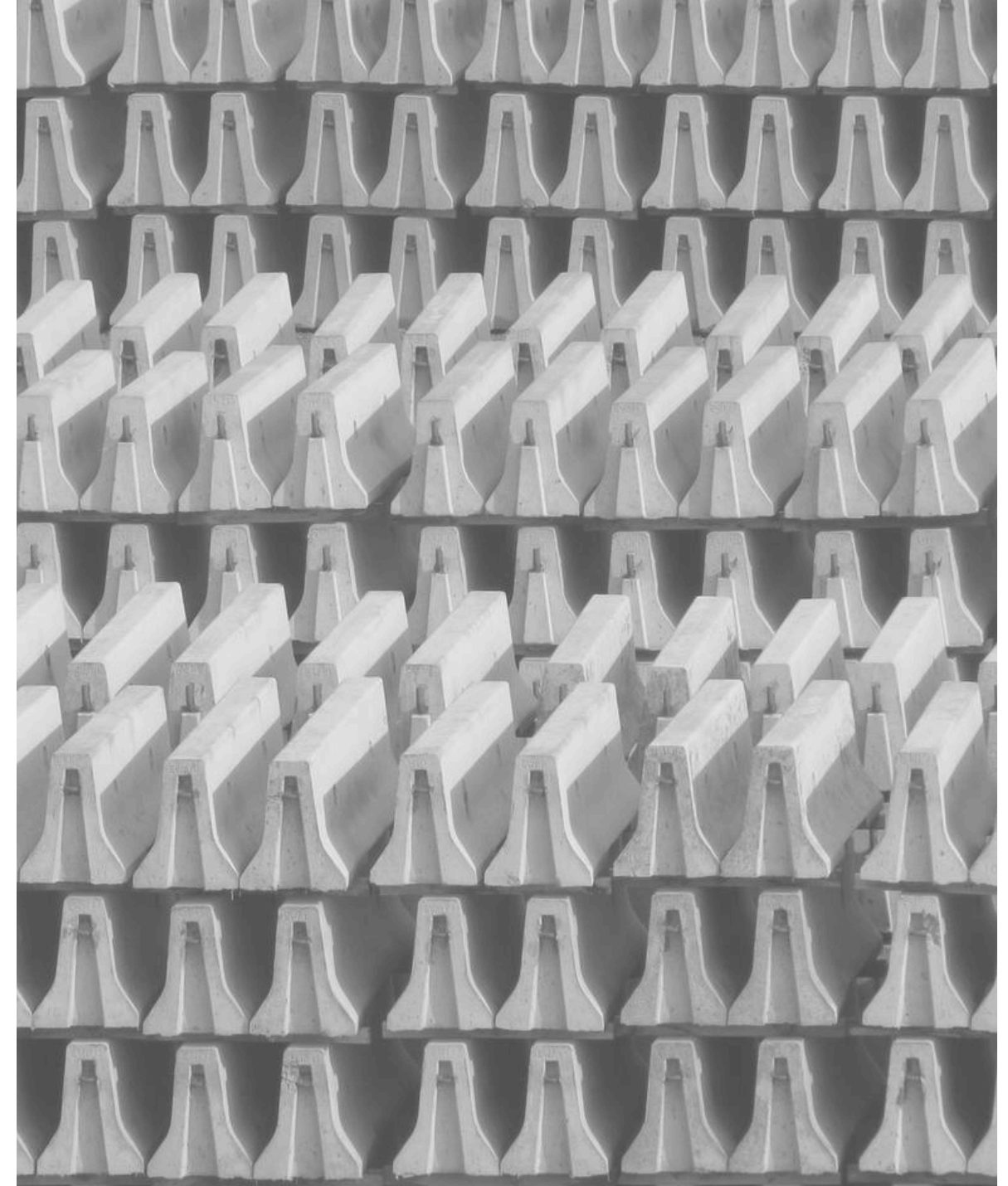

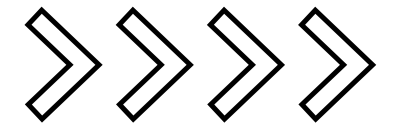

الرؤية والرسالة والقيم الجوهرية ✨

الرؤية: أن نكون الخيار الأول والشركة الرائدة والمتكاملة في تقديم حلول ومنتجات إسمنتية عالية الجودة في المملكة العربية السعودية.

الرسالة: توفير منتجات إسمنتية بمعايير عالمية، مدعومة بمنظومة متكاملة للتصنيع والتوريد، تساهم في تسريع ورفع جودة المشاريع الإنشائية.

القيم الجوهرية: الجودة أولاً، الالتزام بالمواعيد، التكامل التشغيلي، الموثوقية.



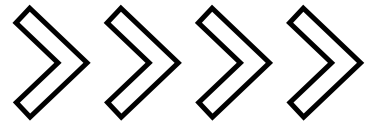

القدرات

قوتنا في التكامل والتحكم 
الصناعات الحديدية وتجهيز القوالب: ورش خاصة لتصميم
وتصنيع قوالب الصب بدقة.
التحكم الكامل في: (Ready Mix) مصنع الخرسانة الجاهزة
جودة الخلطات لضمان أعلى معايير الخرسانة
مواقع التصنيع المتخصصة: مواقع مجهزة لصب ومعالجة
المنتجات الإسمنتية مسبقة الصب



الجودة

الالتزام بأعلى معايير الجودة والسلامة والبيئة 

نفتخر بحصولنا على شهادات: الامتثال الثلاثي

أنظمة الإدارة المتكاملة

الجودة: ISO 9001:2015.

السلامة والصحة المهنية: ISO 45001:2018.

البيئة: ISO 14001:2015.

التصنيف المعتمد: يتم توفير التصنيف اللازم للمنتجات الإسمنتية
حسب المواصفات المطلوبة
ومتطلبات الجهات ذات العلاقة (مثل: شركة المياه الوطنية، الشركة
السعودية للكهرباء، والأمانات)

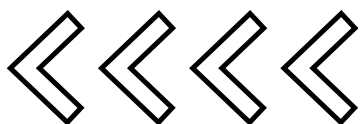



تاريخنا

01

2020

تأسست شركة المطور المعتمد للمقاولات مع رؤية واضحة نحو النمو والأزدهار والمساهمة في مشاريع التنمية لسيدي ولي العهد

02

2022

تم افتتاح قسم الصناعات الأسمنتية لدعم أهداف ومشاريع الشركة التنموية والمساهمة في تحقيق أعلى جودة وسرعة سلاسل التوريد لمشاريع الشركة

03

2023

تحويل قسم الصناعات الأسمنتية الى إدارة منفصلة ومستقلة يعمل حسب متطلبات أيزو وشركة المياه وشركة الكهرباء وأصبح يعمل للبيع الخارجي وتحقيق دخل إضافي للشركة



خدماتنا



المنتجات الاسمنتية

تصنيع المناهيل وأغطية المناهيل والحواجز الأسمنتية بمختلف المقاسات وقواعد مسبقة الصنع وقواعد الأعمدة و البلدورات

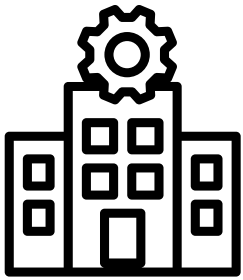

المباني مسبقة الصنع

تصنيع الأسوار مسبقة الصنع وتصنيع المباني مسبقة الصنع

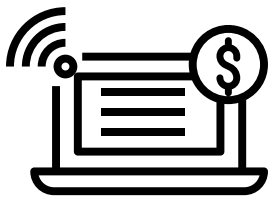

التصنيع المتخصص

من باب رؤيتنا لرضاء العملاء والتوسع لأقصاء شريحة من الشركاء نفخر بقدرتنا في التصنيع المتخصص لأي منتج أسمنتي وحسب طلب العميل وتصميمه .



منظومة الإنتاج المتكاملة

نحن نفخر بامتلاك وتشغيل منظومة إنتاجية متكاملة تضمن أعلى مستويات الجودة والتحكم في دورة التصنيع بأكملها، بما في ذلك

(Ready Mix Plant) مصنع الخرسانة الجاهزة

منشأة متخصصة لإنتاج الخرسانة بمختلف الدرجات والمواسفات. التحكم الداخلي في خلطات الخرسانة يضمن الجودة والقوة اللازمة لجميع منتجاتنا الإسمنتية مسبق الصب

مواقع التصنيع المتخصصة للمنتجات الإسمنتية

مواقع مجهزة بأحدث الآلات والقوالب لعمليات صب ومعالجة المنتجات. مثل حواجز نيوجيرسي، البلدورات، المناهيل والقواعد (Precast) الإسمنتية

قسم الصناعات الحديدية وتجهيز القوالب

نمتلك ورشنا الخاصة لتصميم وتصنيع قوالب الصب بدقة هندسية عالية. هذا التكامل يتيح لنا المرونة في تنفيذ التصاميم المخصصة وسرعة الاستجابة لمتطلبات المشاريع.

مرافق الفحص والاختبارات

الالتزام بالجودة ينبع من عمليات الفحص المخبري المستمرة للمواد الأولية والمنتجات النهائية، لضمان المطابقة الكاملة للمواصفات المطلوبة

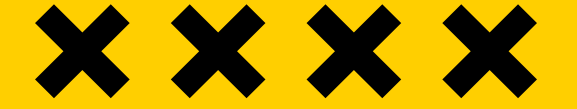

بعض أعمالنا ××××





المطور المعتمد
للمقاولات



250 X 200 X 100cm **N0086**



200 X 200 X 100cm **N0085**

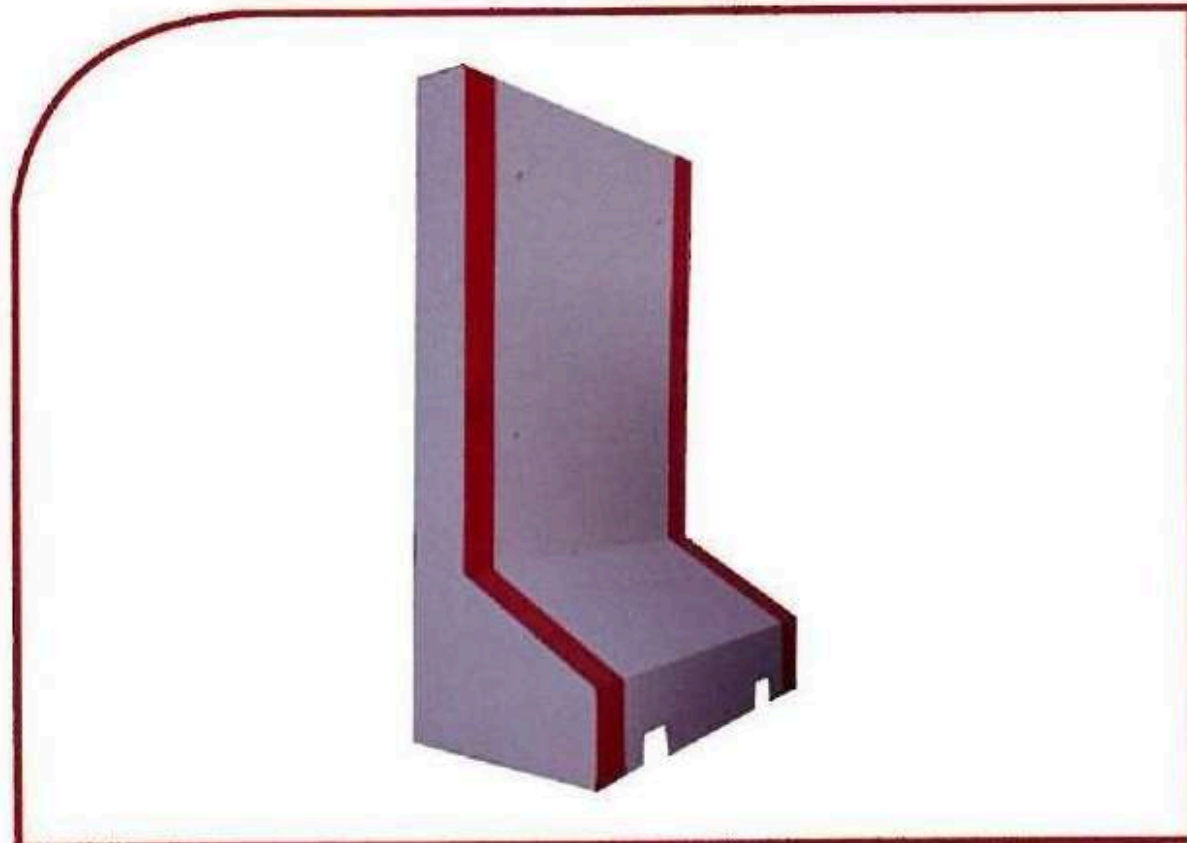

300 x 250 x 100cm **N0088**



300 X 200 X 100cm **N0087**



المطور المعتمد
للمقاولات

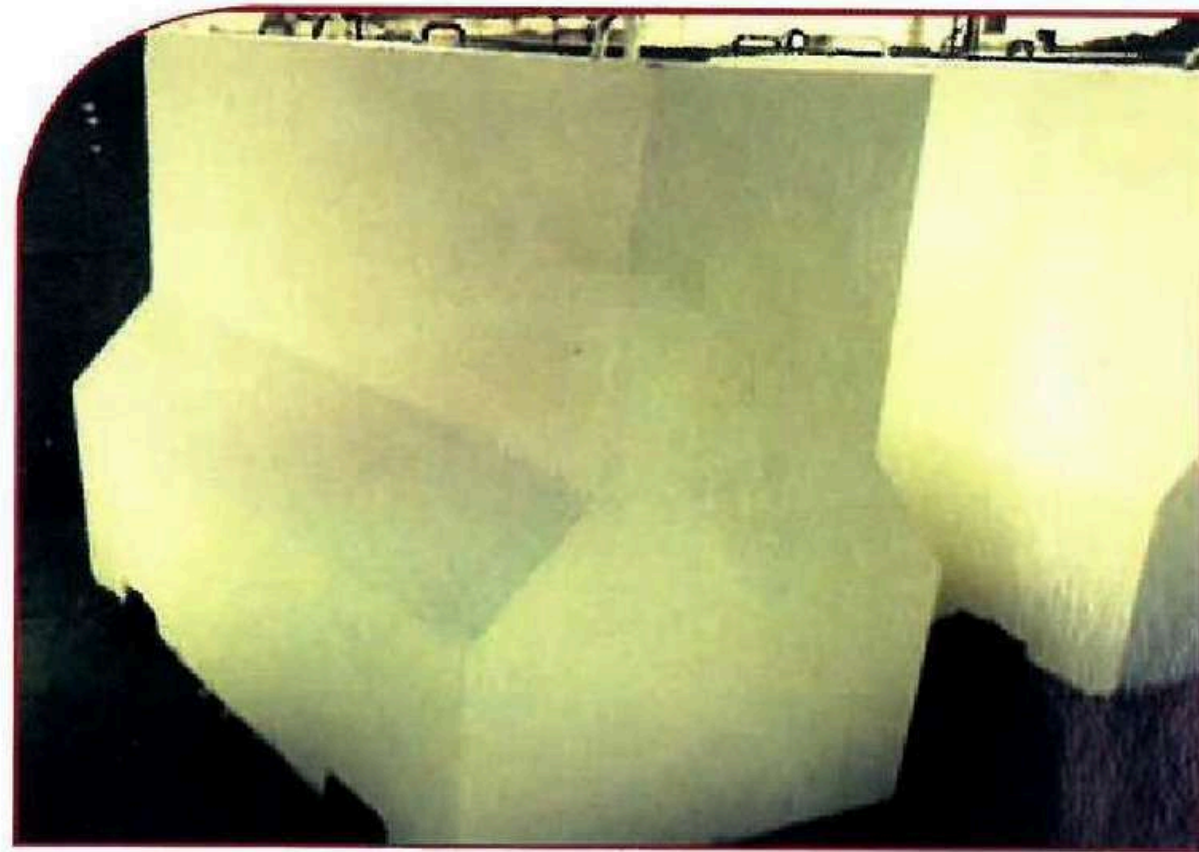

150 X 150 x 70cm

N0082



250 X 100 X 55cm

N0081



200 X 200 X 80cm

N0084

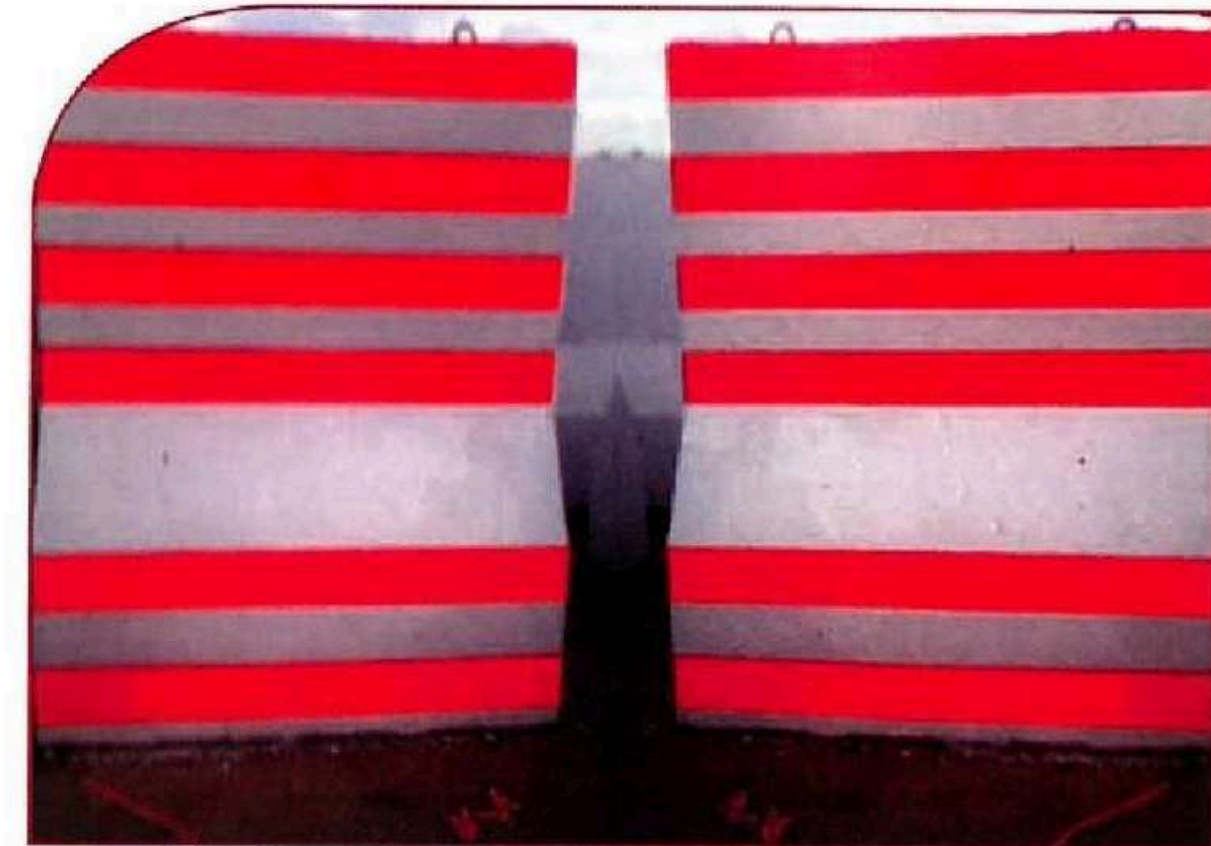

250 X 200 X 80cm

N0083



المطور المعتمد
للمقاولات



100 X 85 X 50cm

N0078

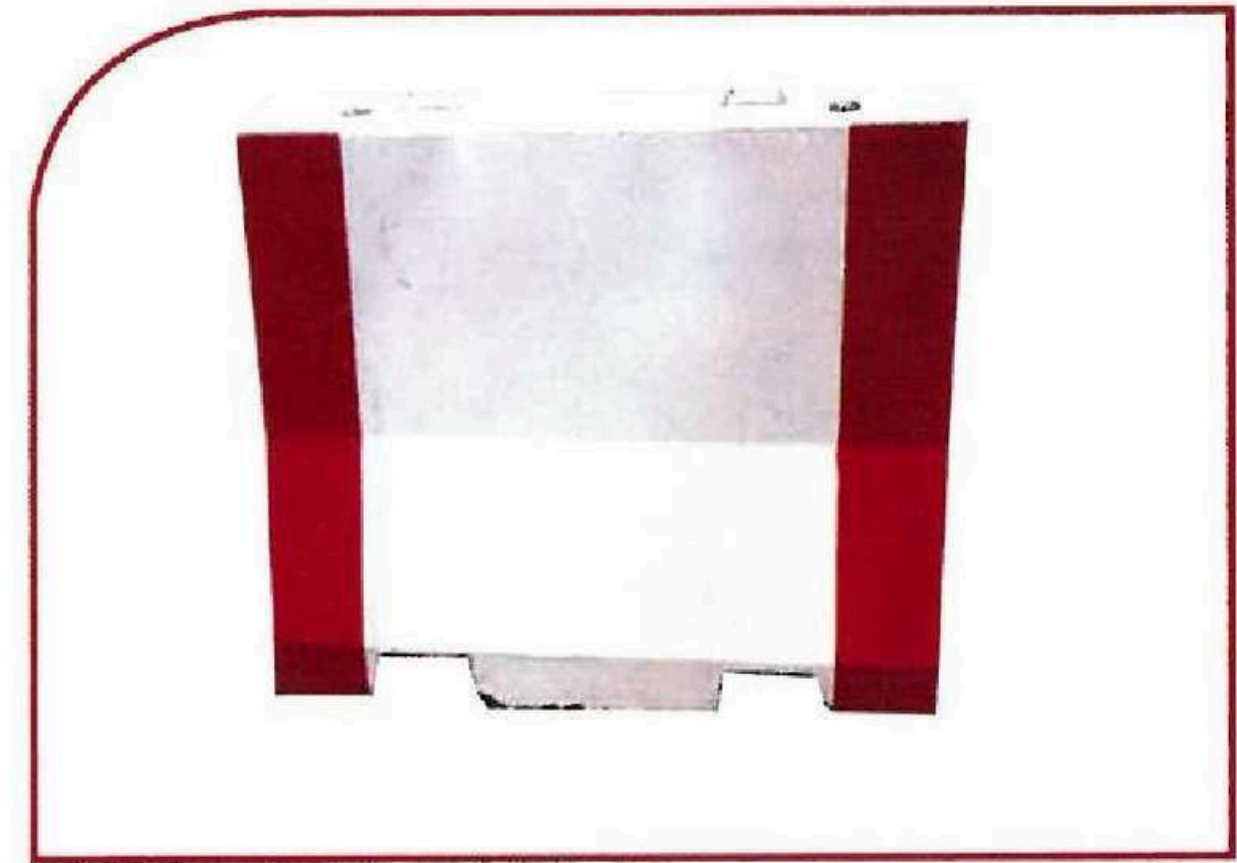

100 X 100 X 60cm

N0077



150 X 100 X 55cm

N0080

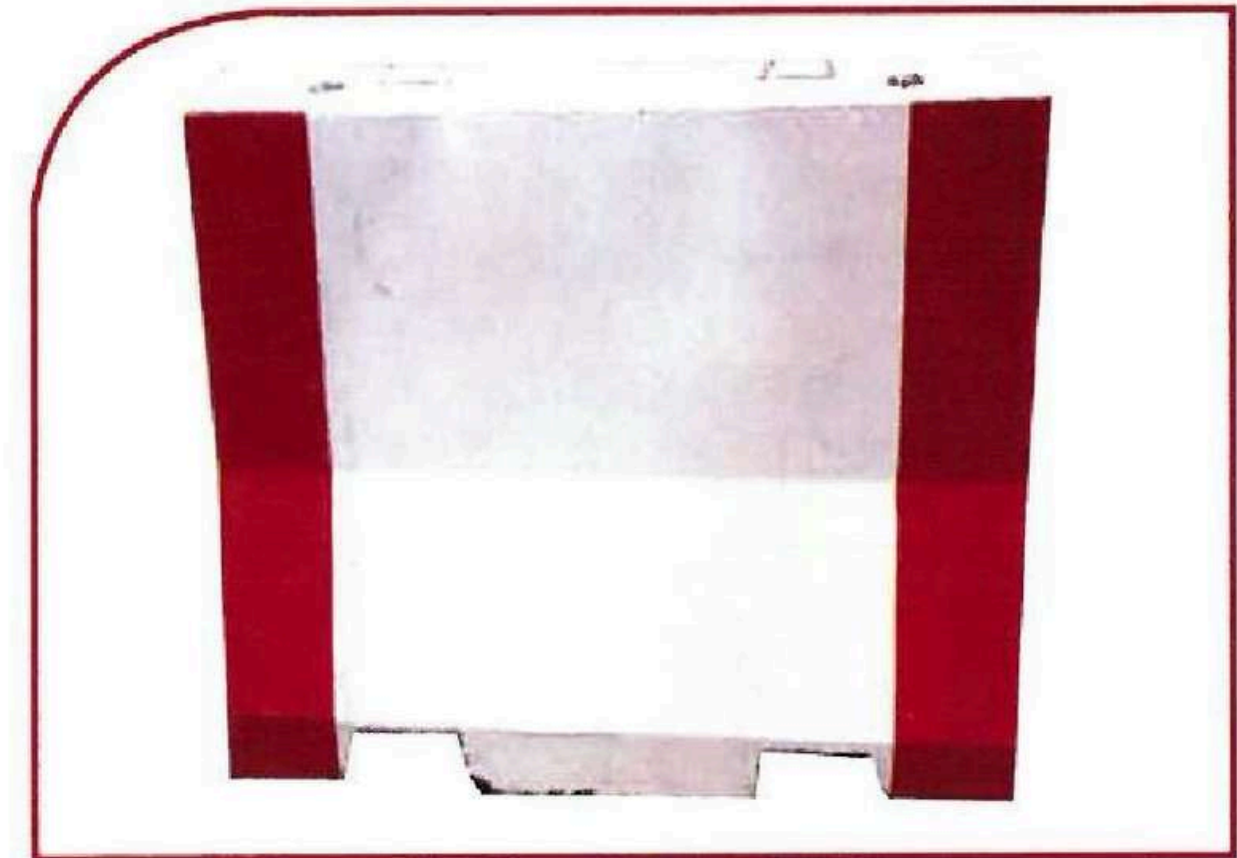

120 x 100 x 55cm

N0079



المطور المعتمد
للمقاولات



300 X 200 X 100cm **N0090**



200 X 200 X 80cm **N0089**



150 X 100 X 55cm **N0092**



250 X 200 X 80cm **N0091**



المطور المعتمد
للمقاولات



ماكينة صب بر دورات جميع مقاسات الأرصفة

(نيوجيرسي مطابقة لمواصفات وزارة النقل) (High Way)



المطور المعتمد
للمقاولات

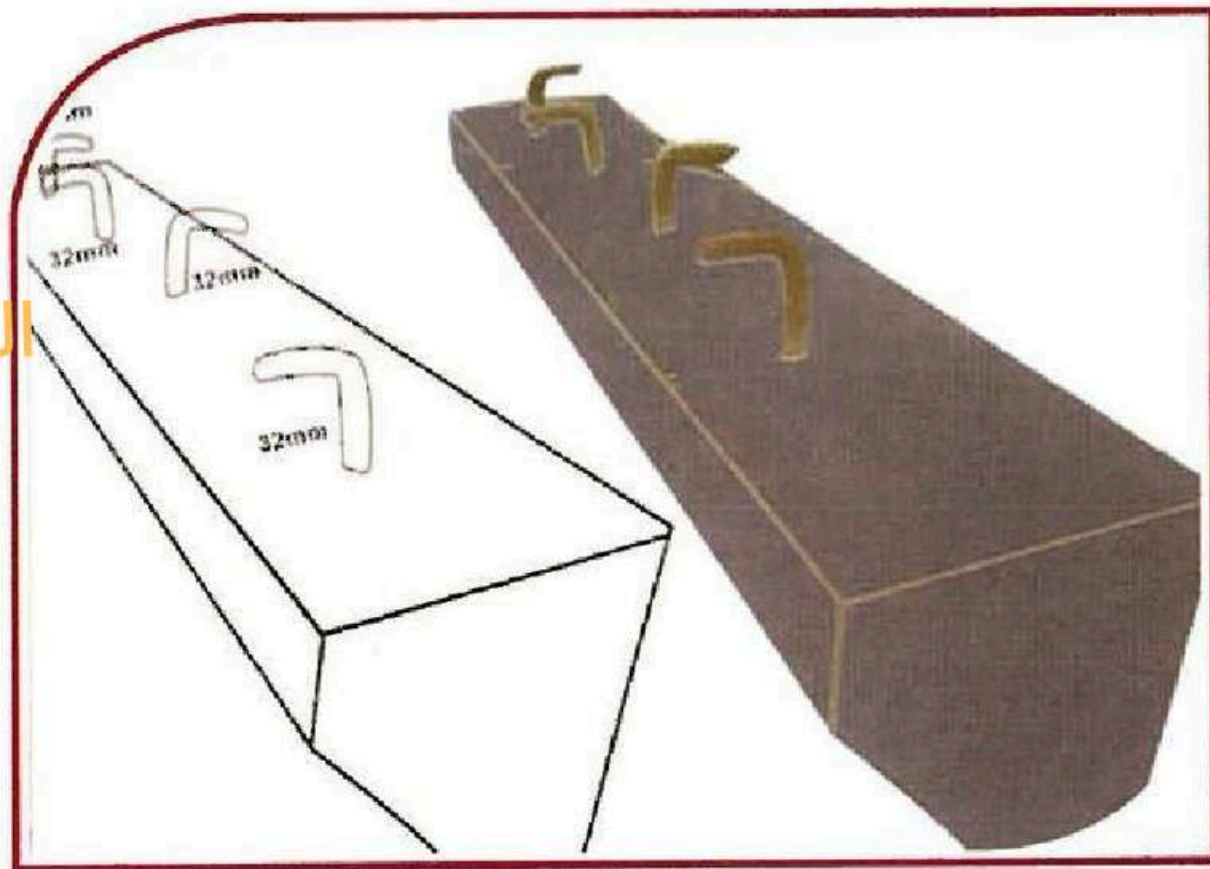

(250x43x90cm)

N0094



N0093

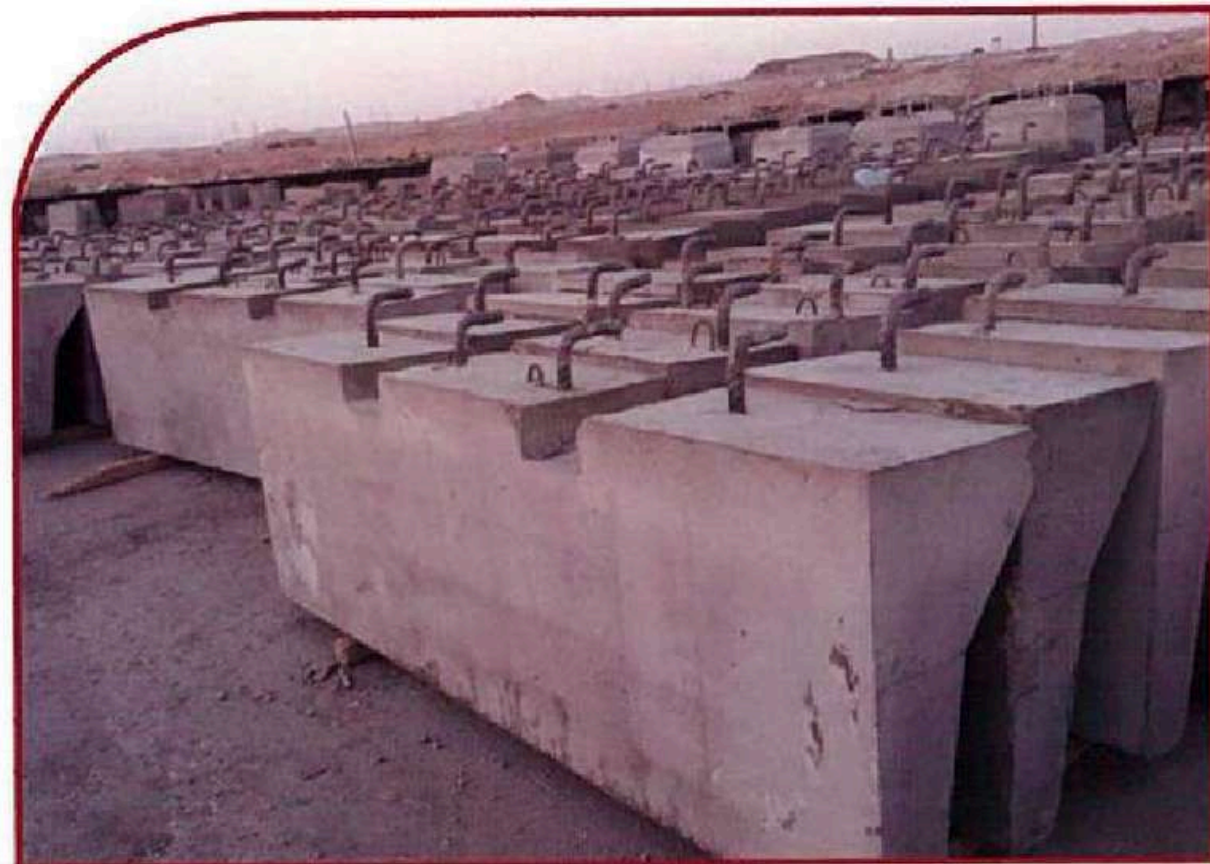

N0096



N0095

حسب الطلب متوفرة جميع المقاسات وطبقاً للمواصفات (بترات لتقسيم الأراضي)



المطور المعتمد
للمقاولات



M0002



M0001



M0004



M0003



المطور المعتمد
للمقاولات

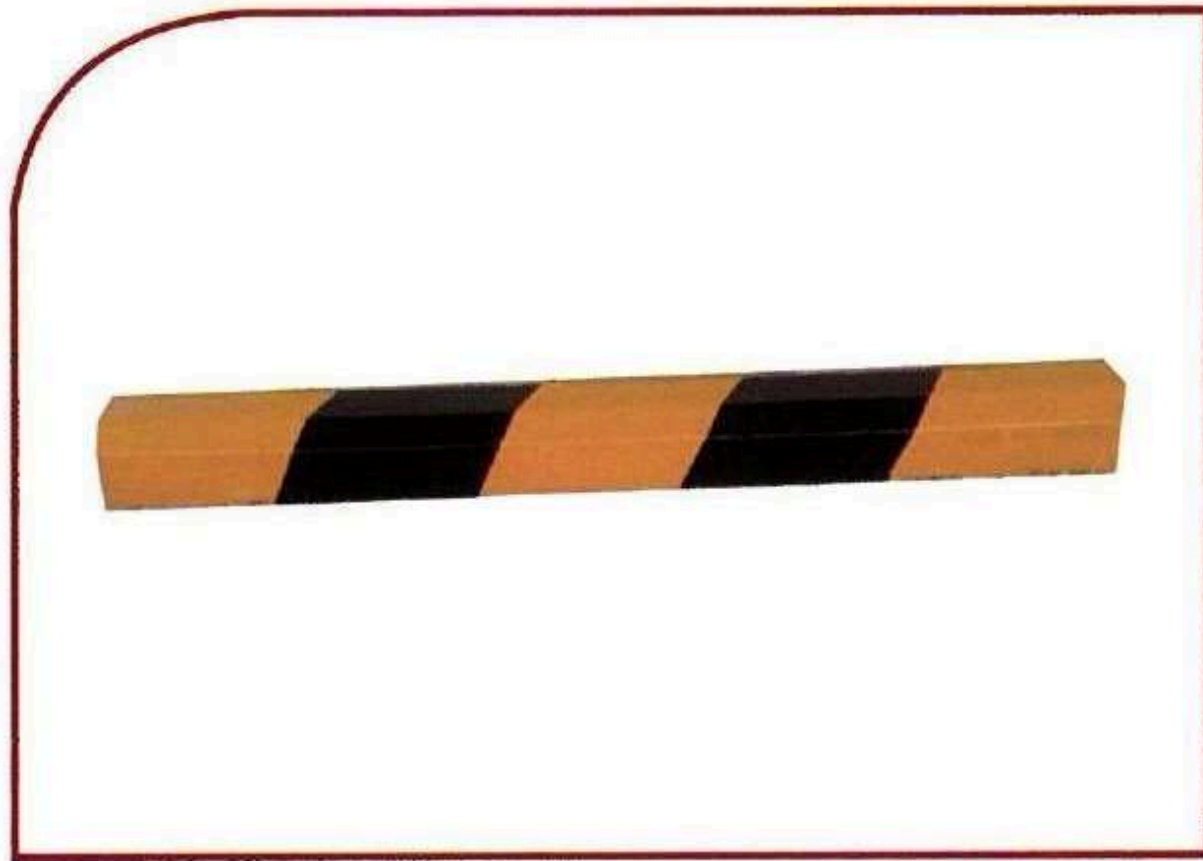

180 X 35 X 25cm **N0098**

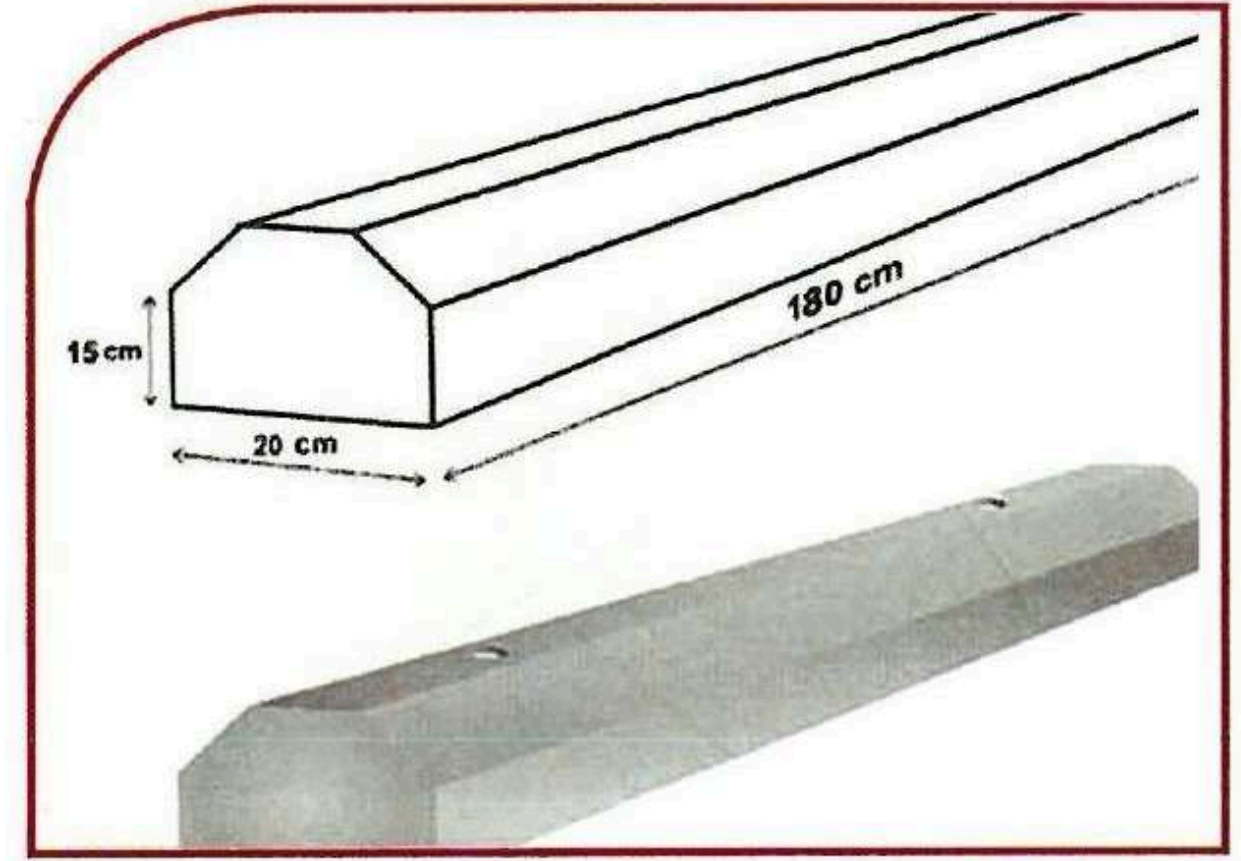

180 X 20 X 15cm **N0097**

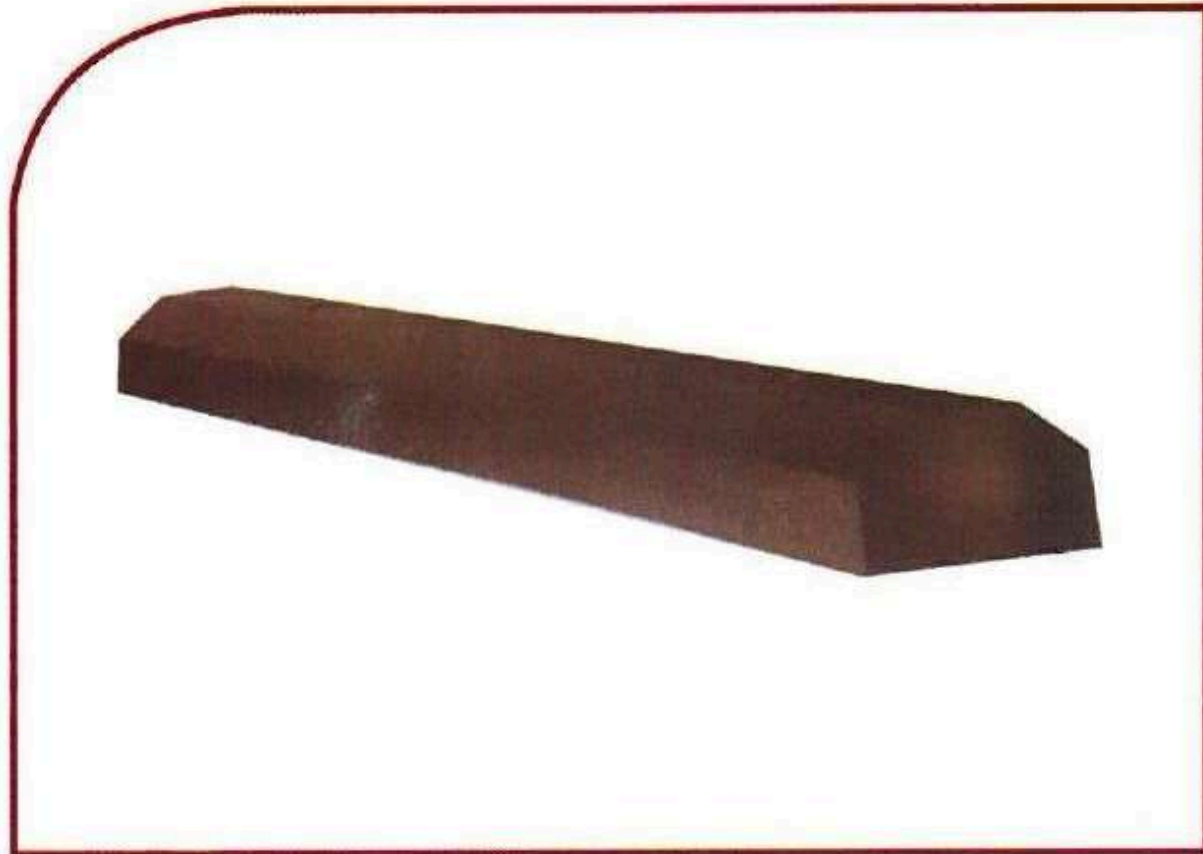

150 x 30 x 20cm **N0100**

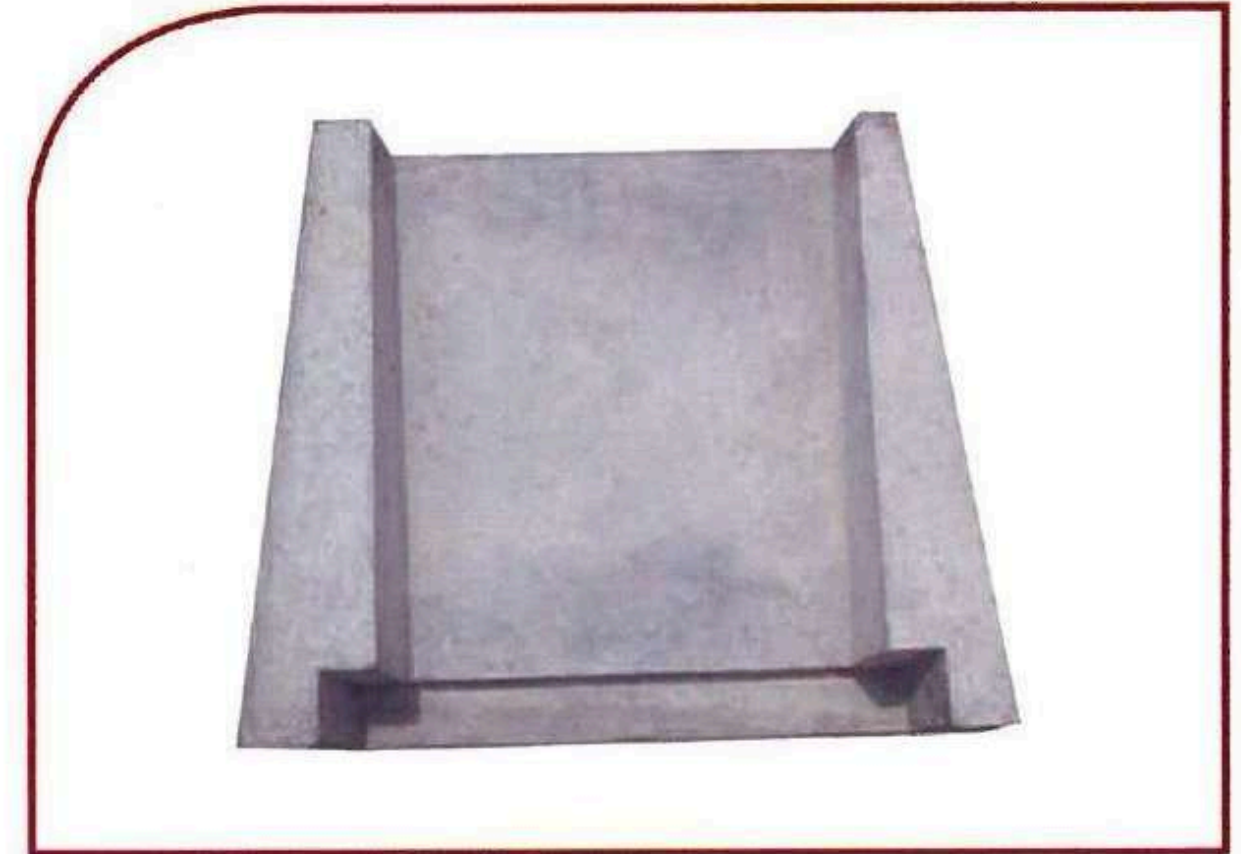

45 X 45 X 15 cm **N0099**

قواعد كهربائية



المطور المعتمد
للمقاولات

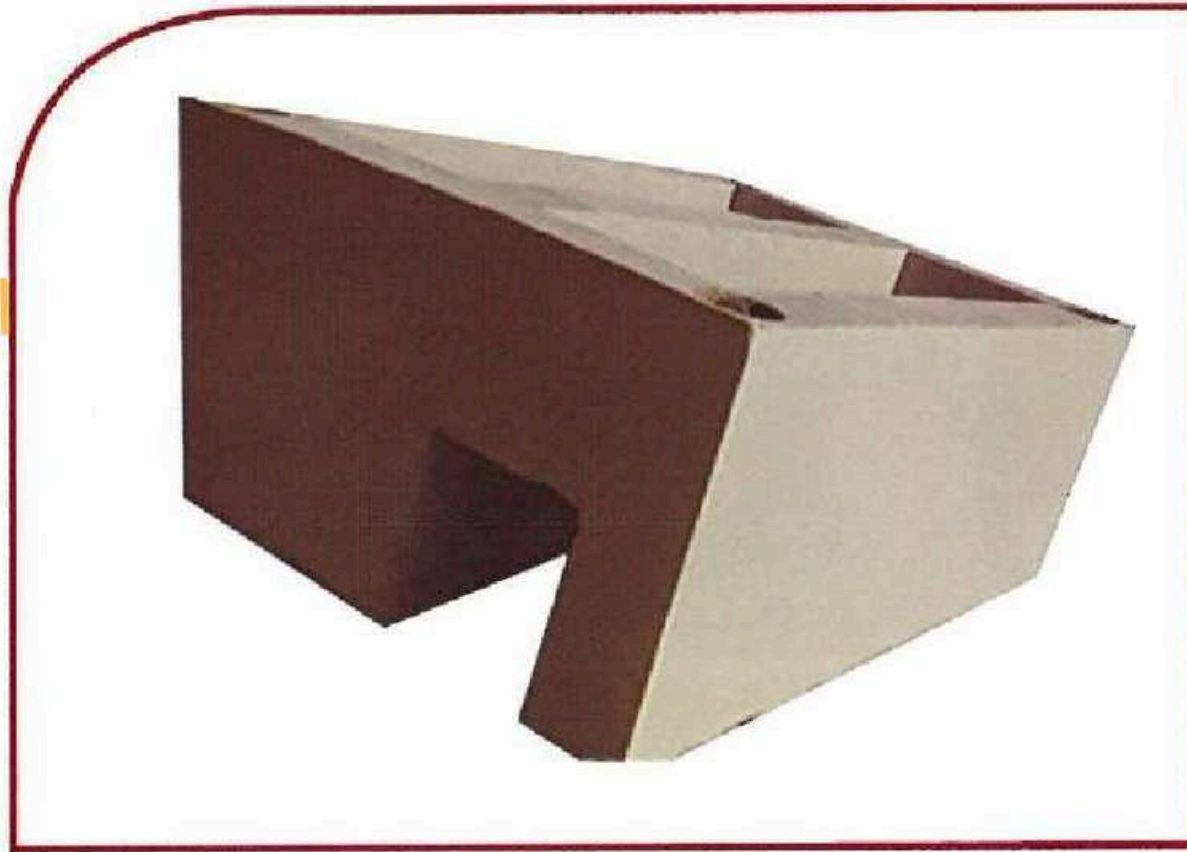

Size(1000) → 210x160x100x20 **M0006**

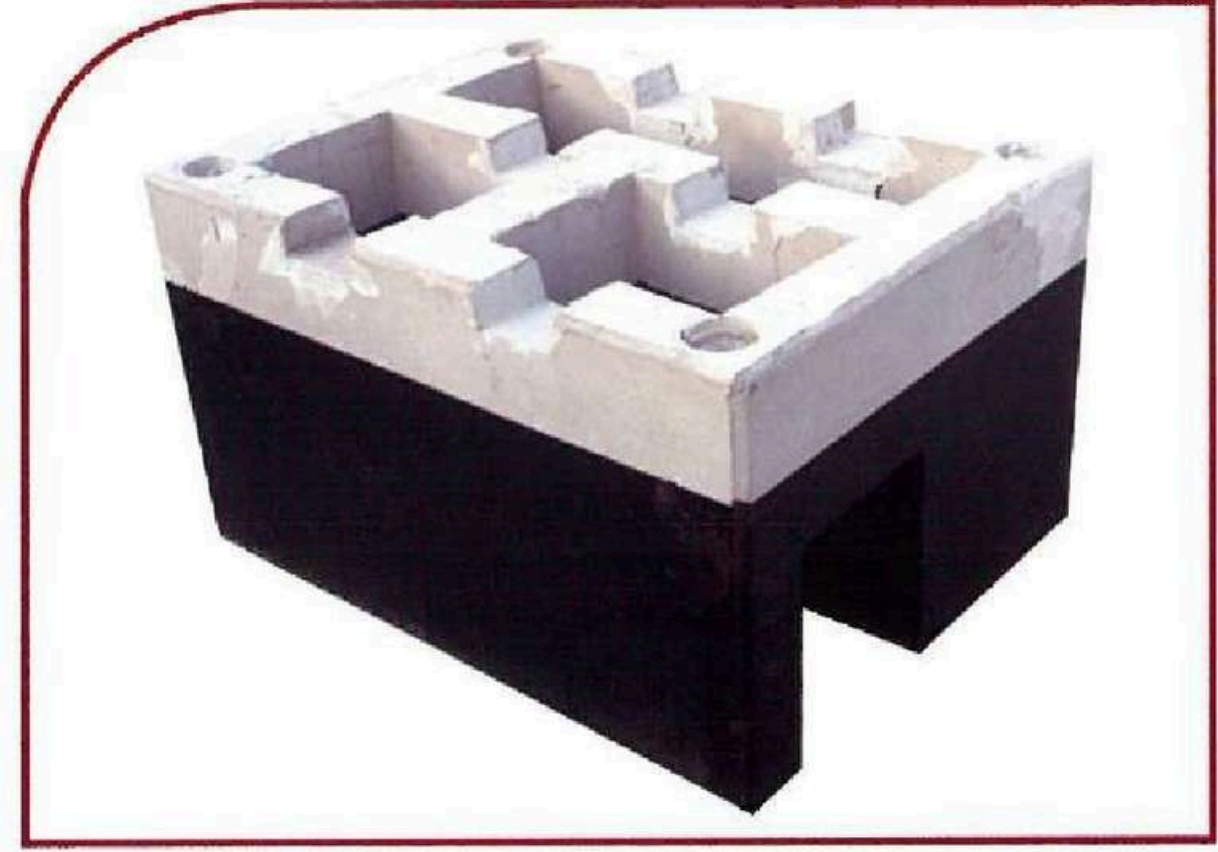

Size(1000) → 200x150x110x20 **M0005**

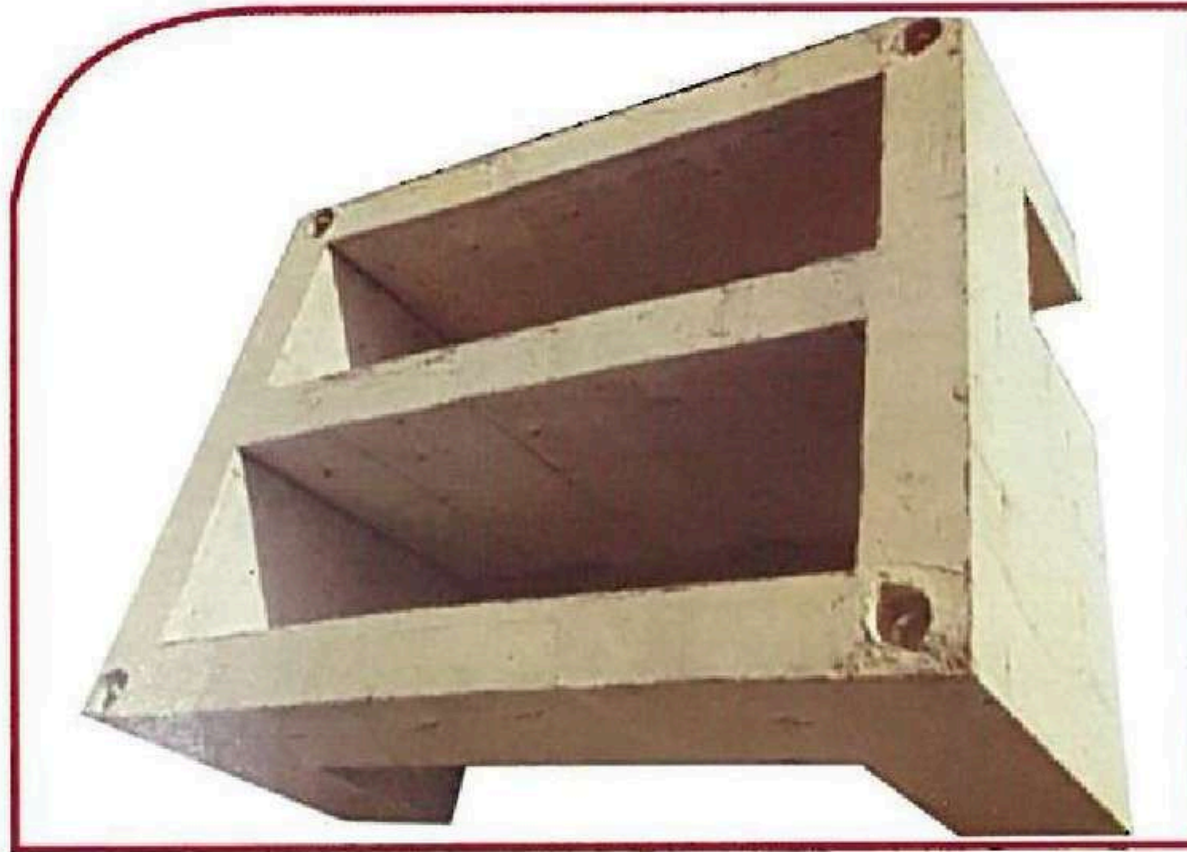

Size(1500) → 230x180x100x20 **M0008**

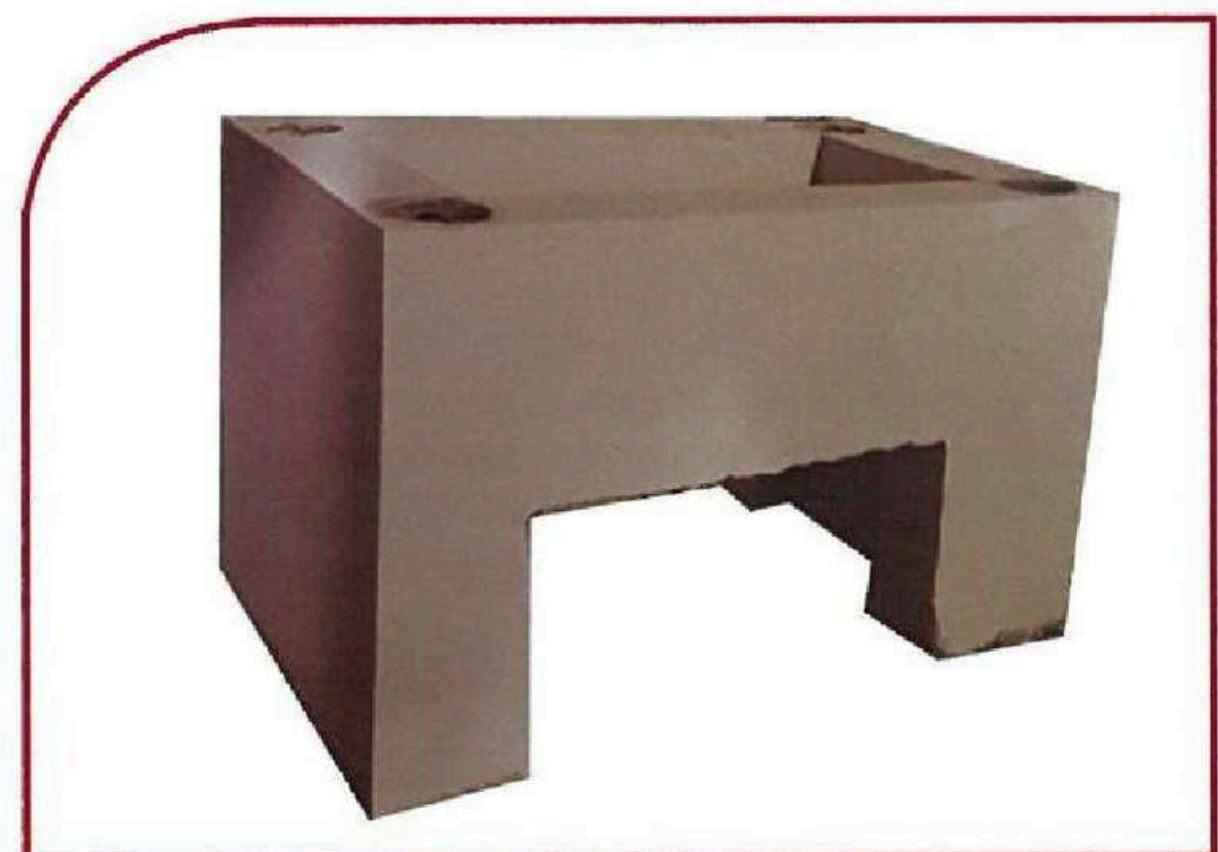

Size(500) → 150x100x100x20 **M0007**

قواعد كهربائية



المطور المعتمد
للمقاولات



250 x 100 x 100cm

M0010

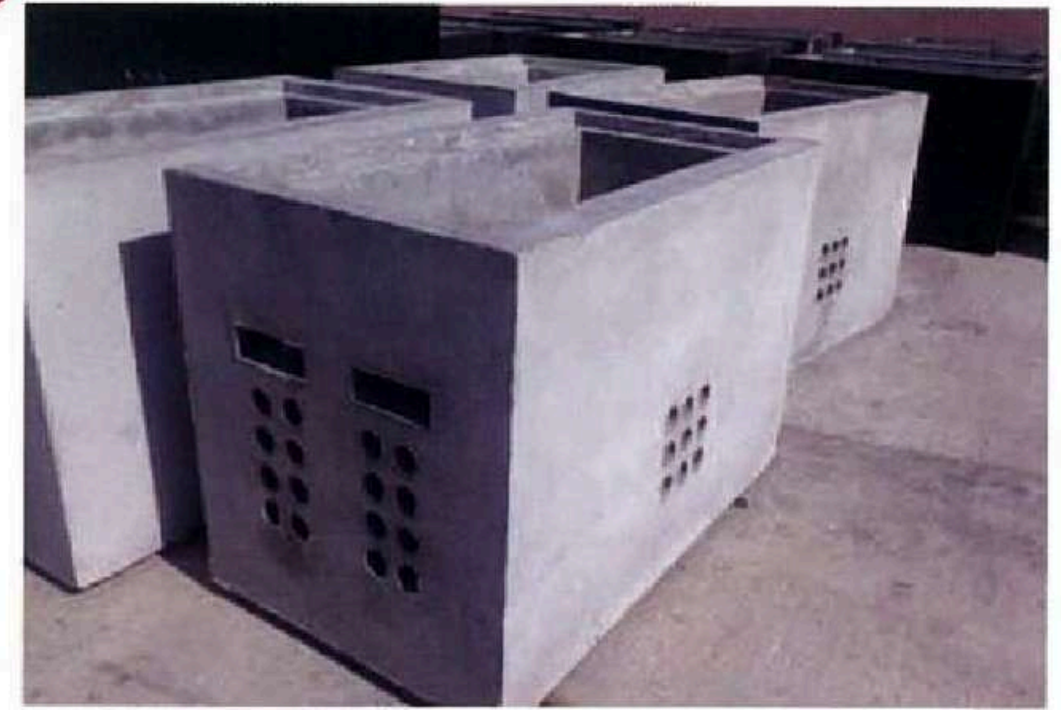

130X100X130cm

M0009



120X100X100cm

M0012

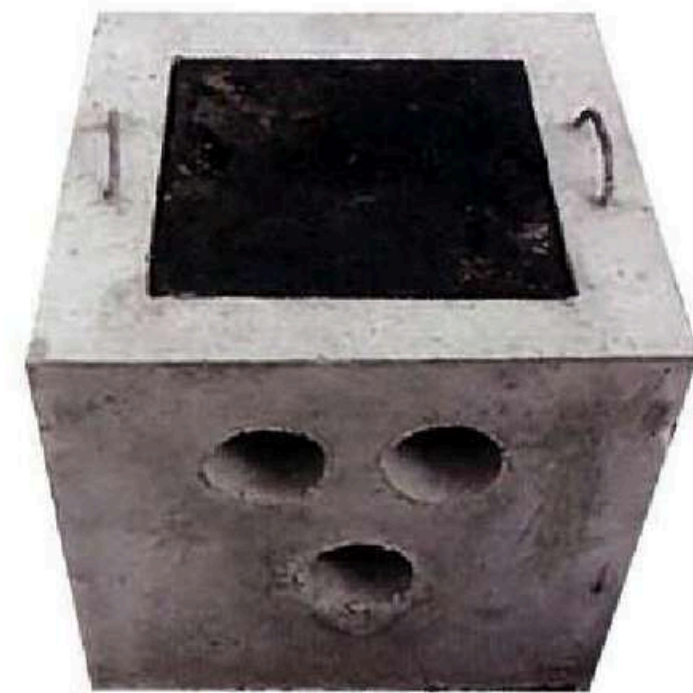

100X80X80cm

M0011

مناهل اتصالات



المطور المعتمد
للمقاولات



80 X 80 X 80CM

M0014



160 X 100 X 100CM

M0013

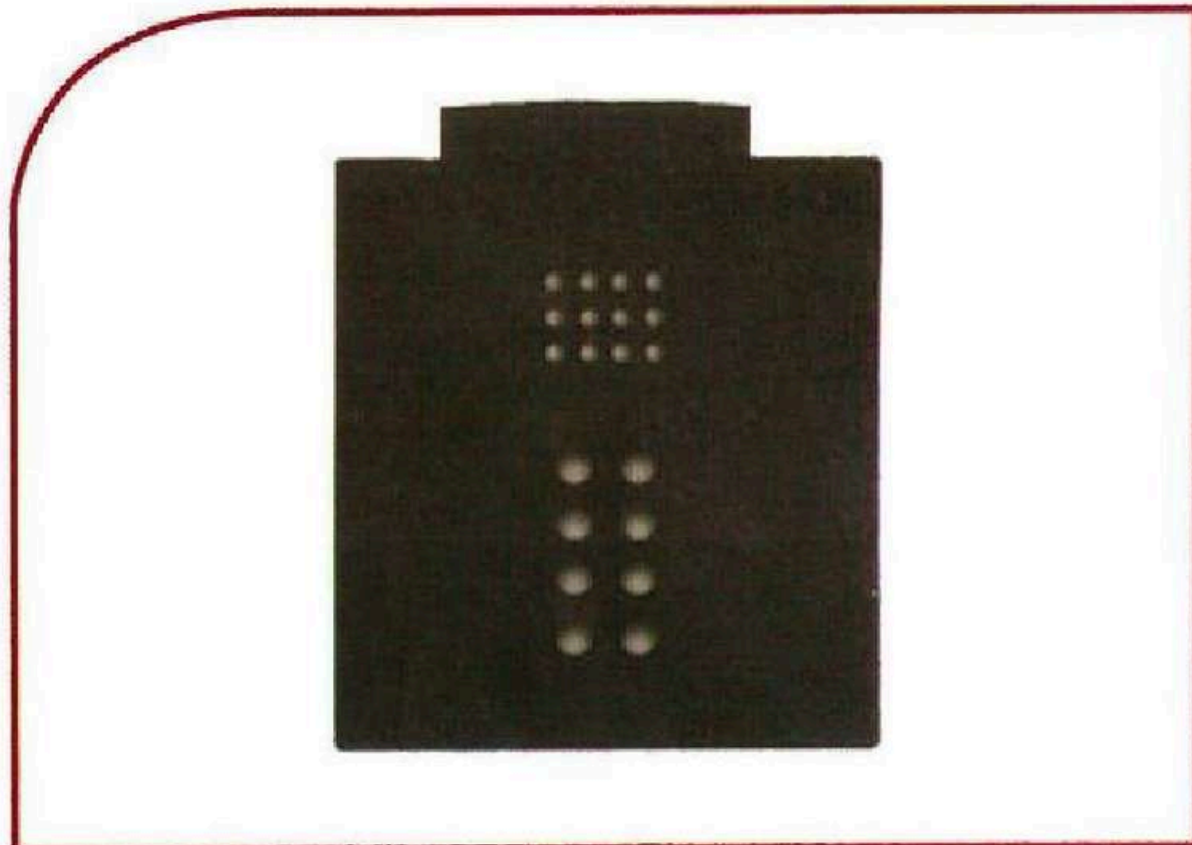

150 X 150 X 180CM

M0016

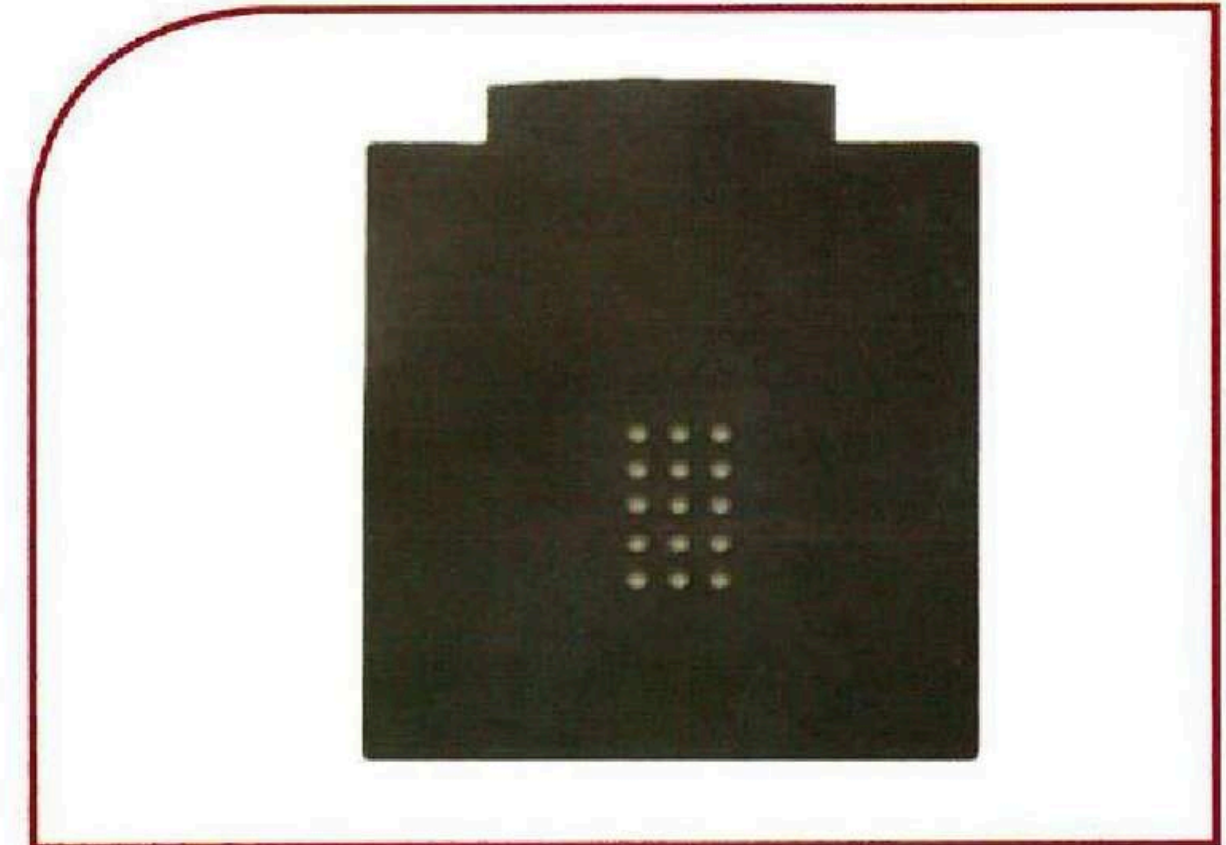

155 X 155 X 160cm

M0015



المطور المعتمد
للمقاولات

غرف تفتيش



60 X 60 X 110cm

M0018

غرف تفتيش

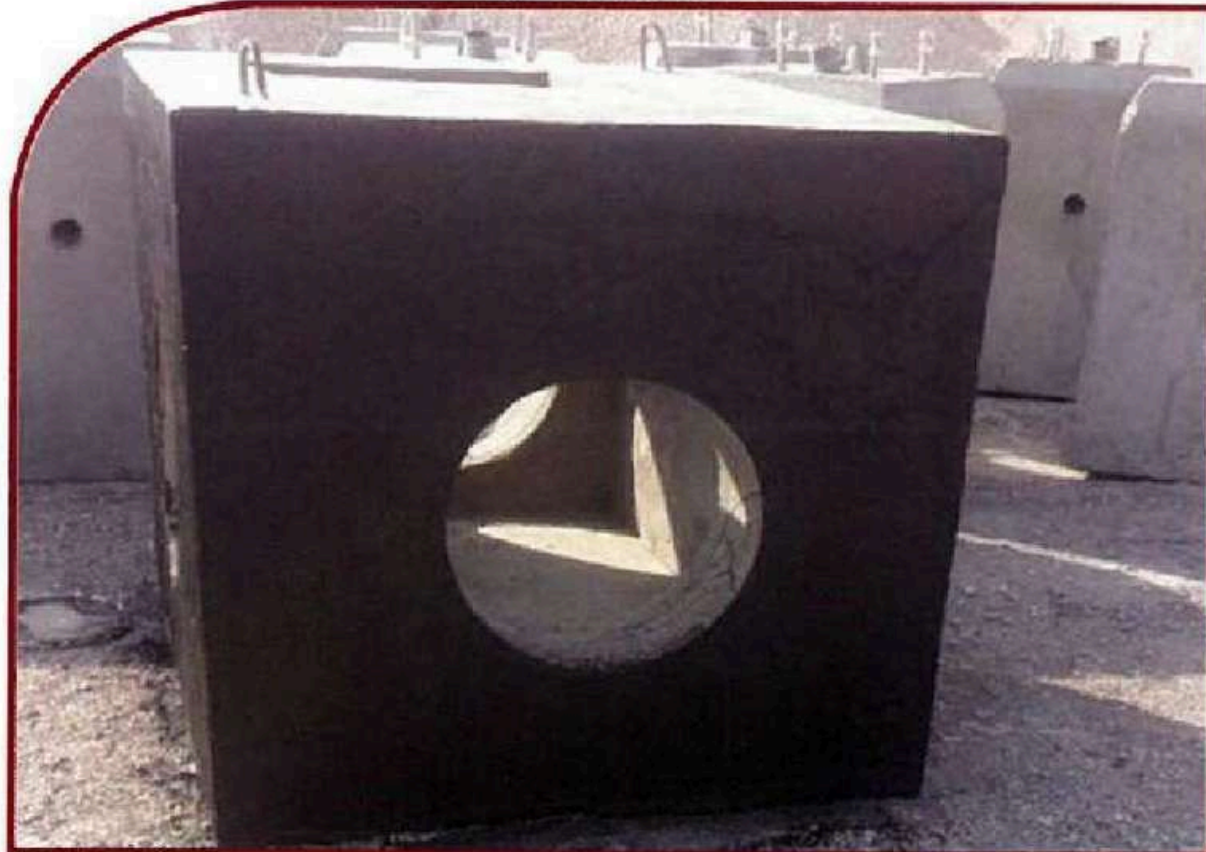

100 X 100 X 120cm

M0020

مصائد صرف السيول

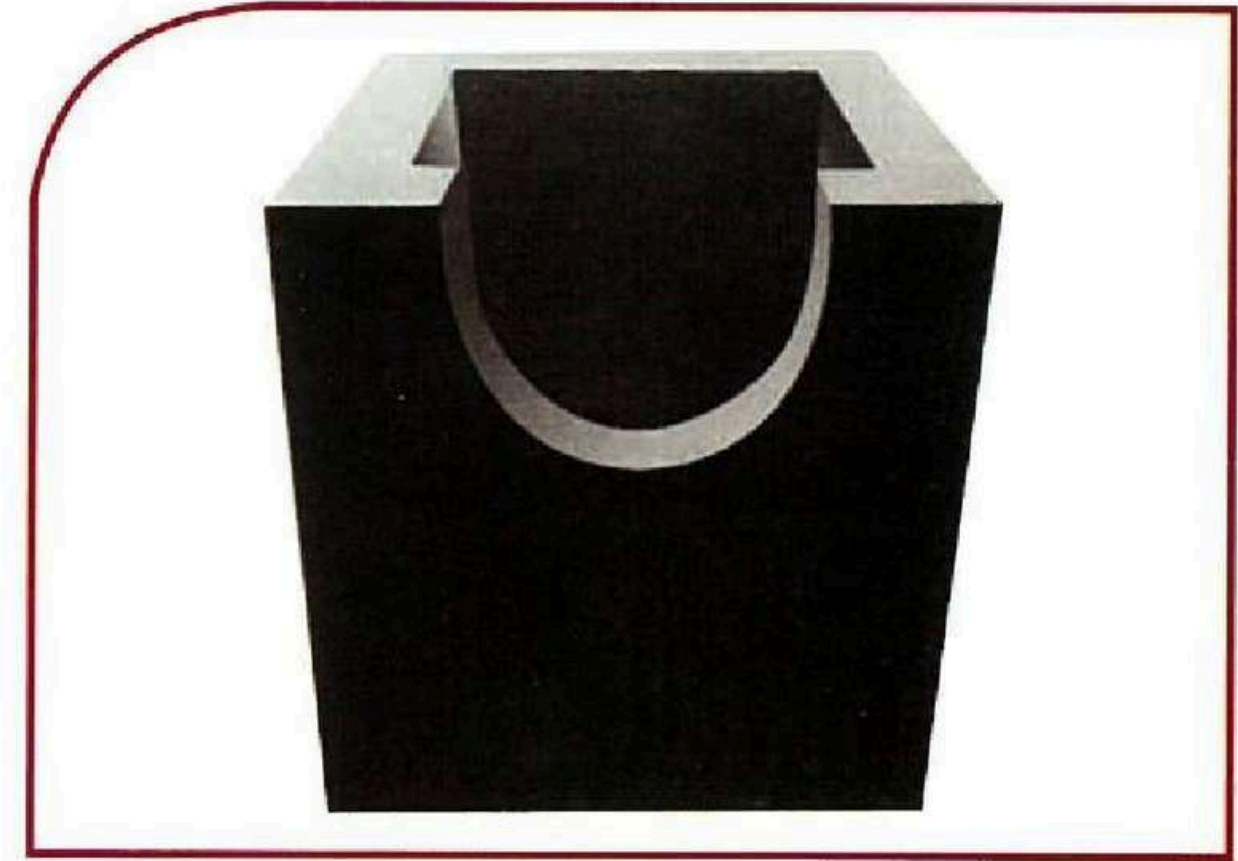

120 x 120 x 80cm

M0017

مطابق دائرية قطر (120 cm)



M0019

قواعد أنارة حسب المقاسات و المواصفات



المطور المعتمد
للمقاولات

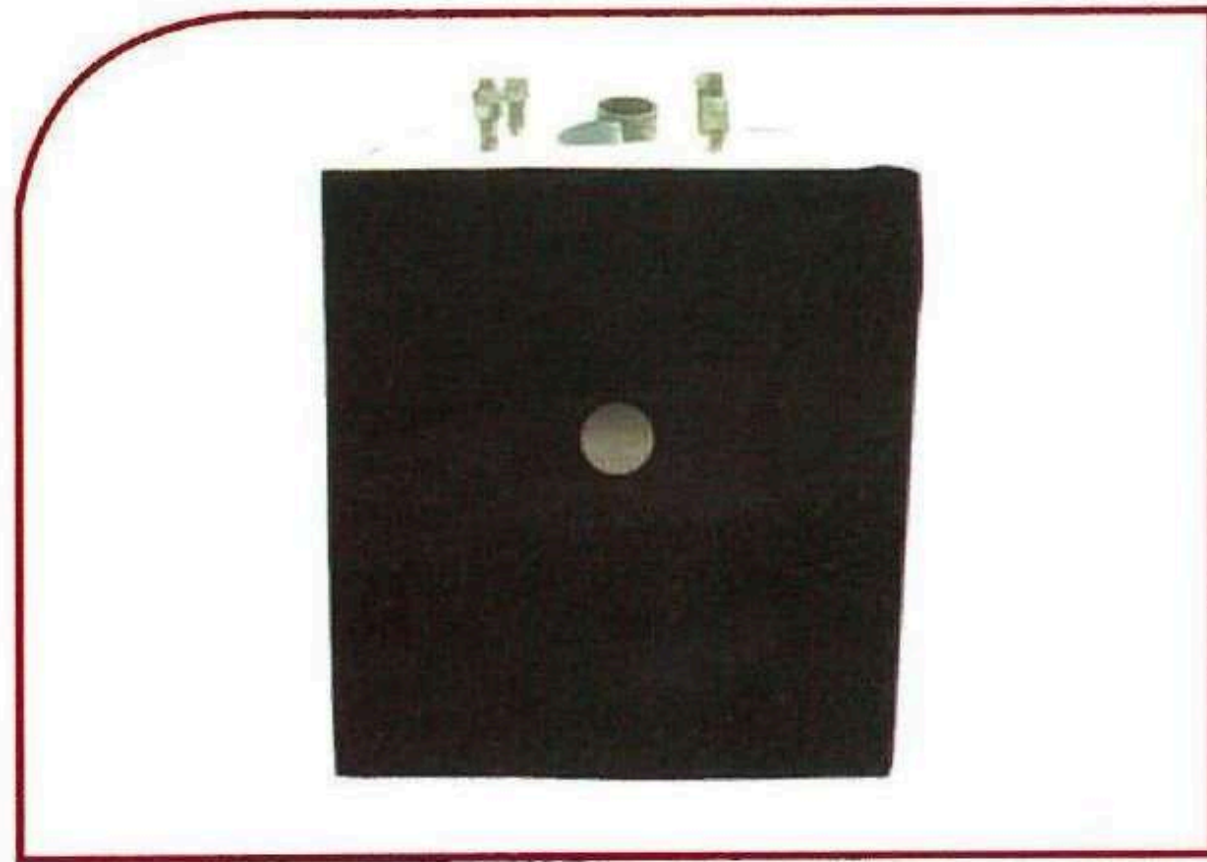

80 X 80 X 80cm

L0002

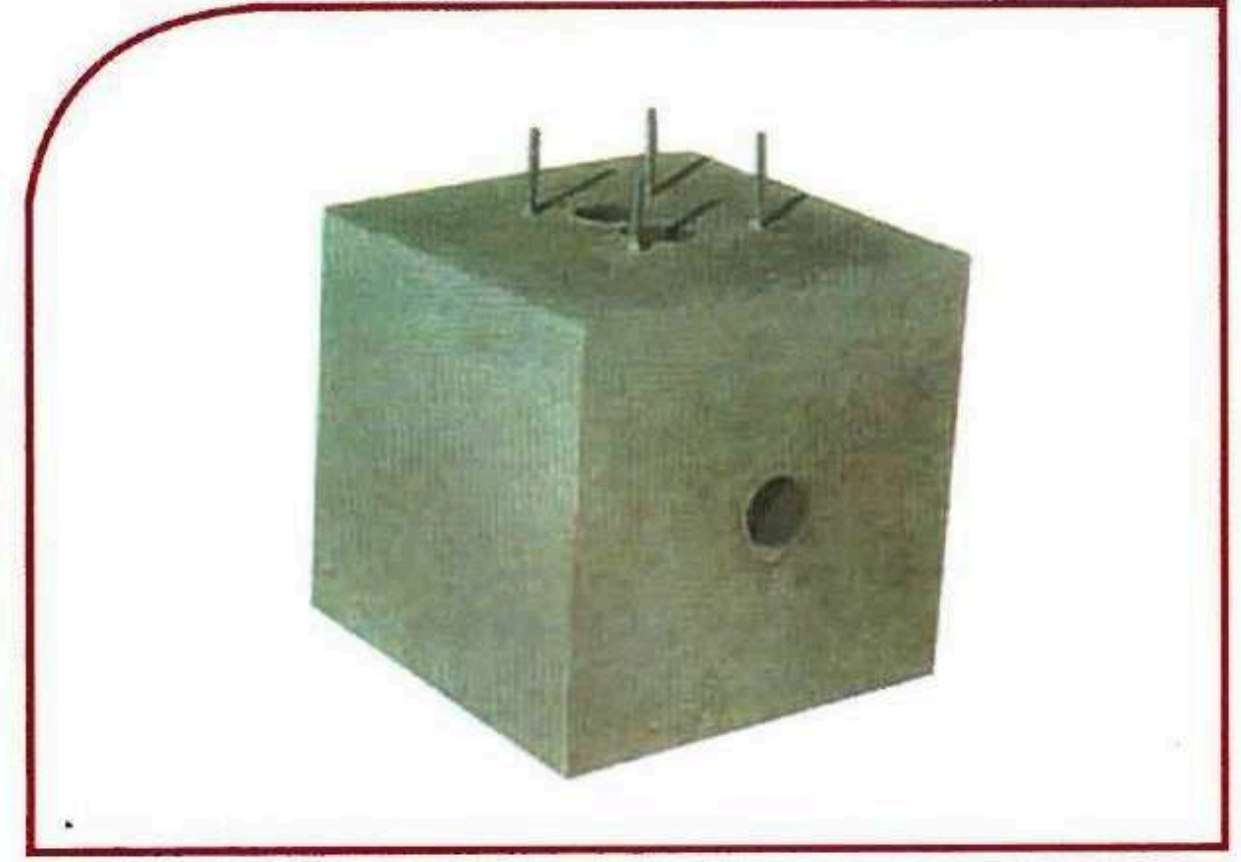

60 X 60 X 60cm

L0001



50 X 50 X 70cm

L0004

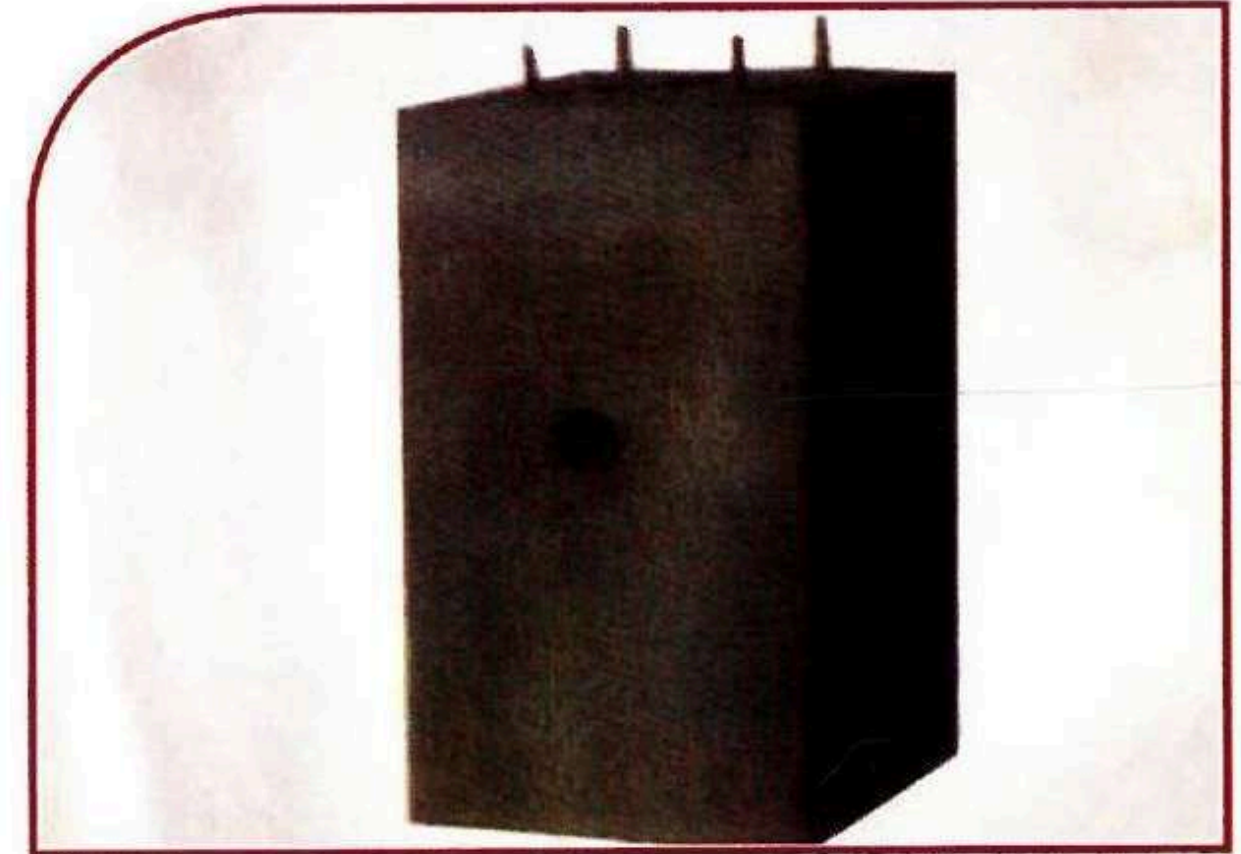

70 X 70 X 140cm

L0003

قواعد أنارة حسب المقاسات و طبقاً للمواصفات



المطور المعتمد
للمقاولات

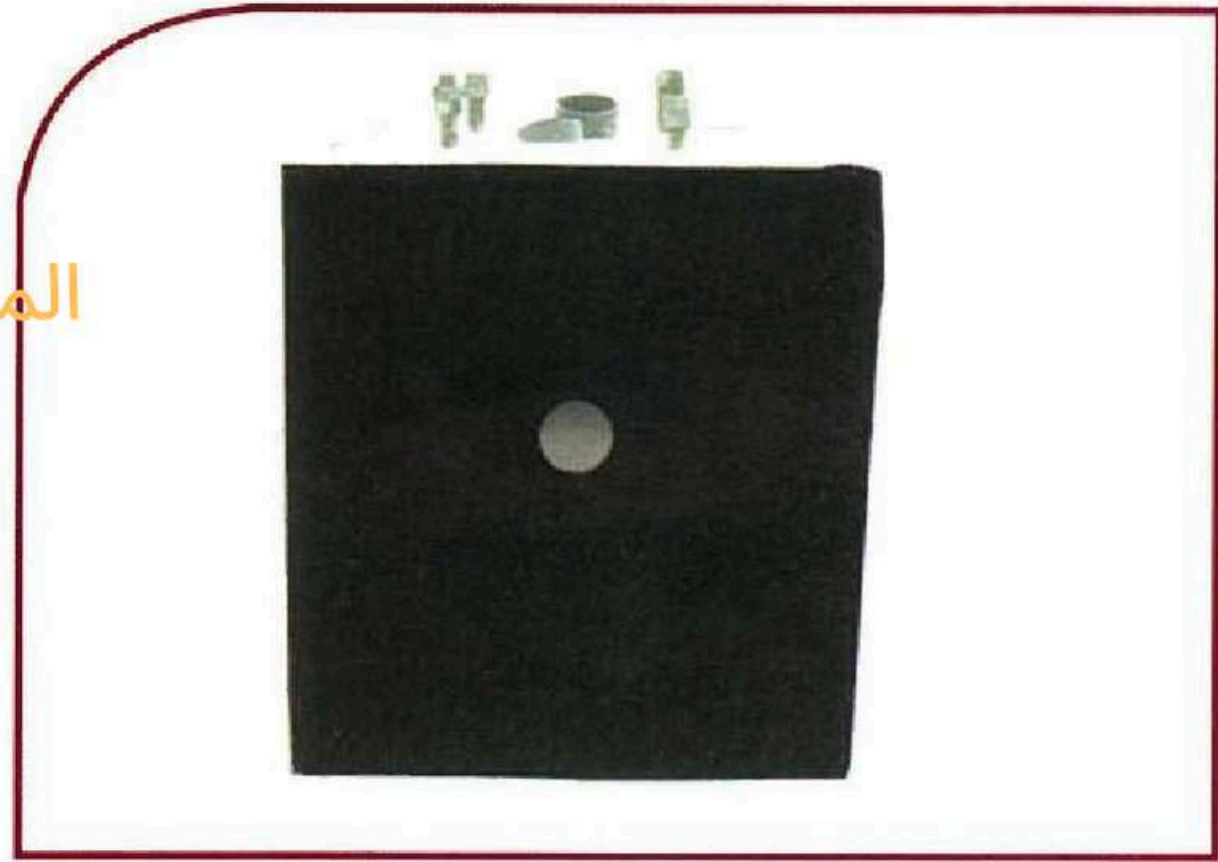

70 x 70 x 100cm

L0006



50 x 50 x 100cm

L0005

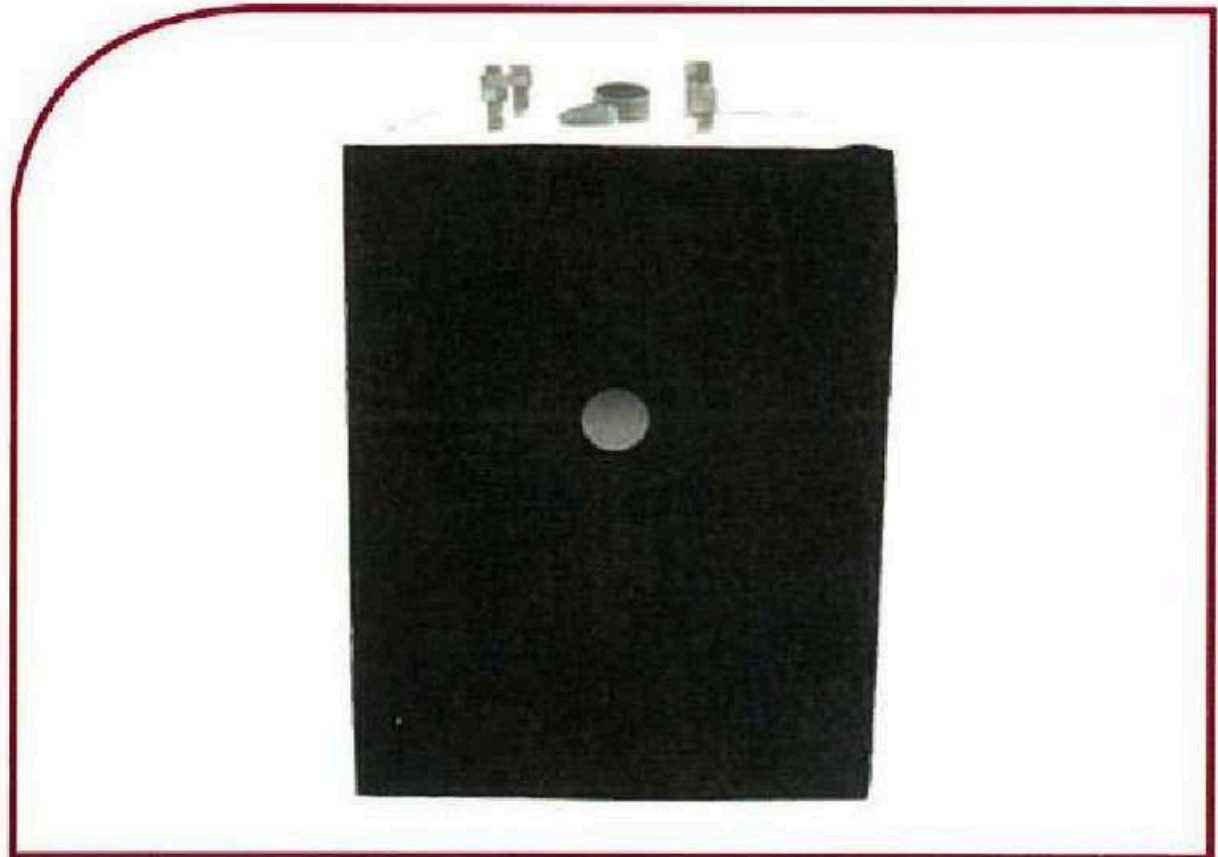

100 x 100 x 160cm

L0008

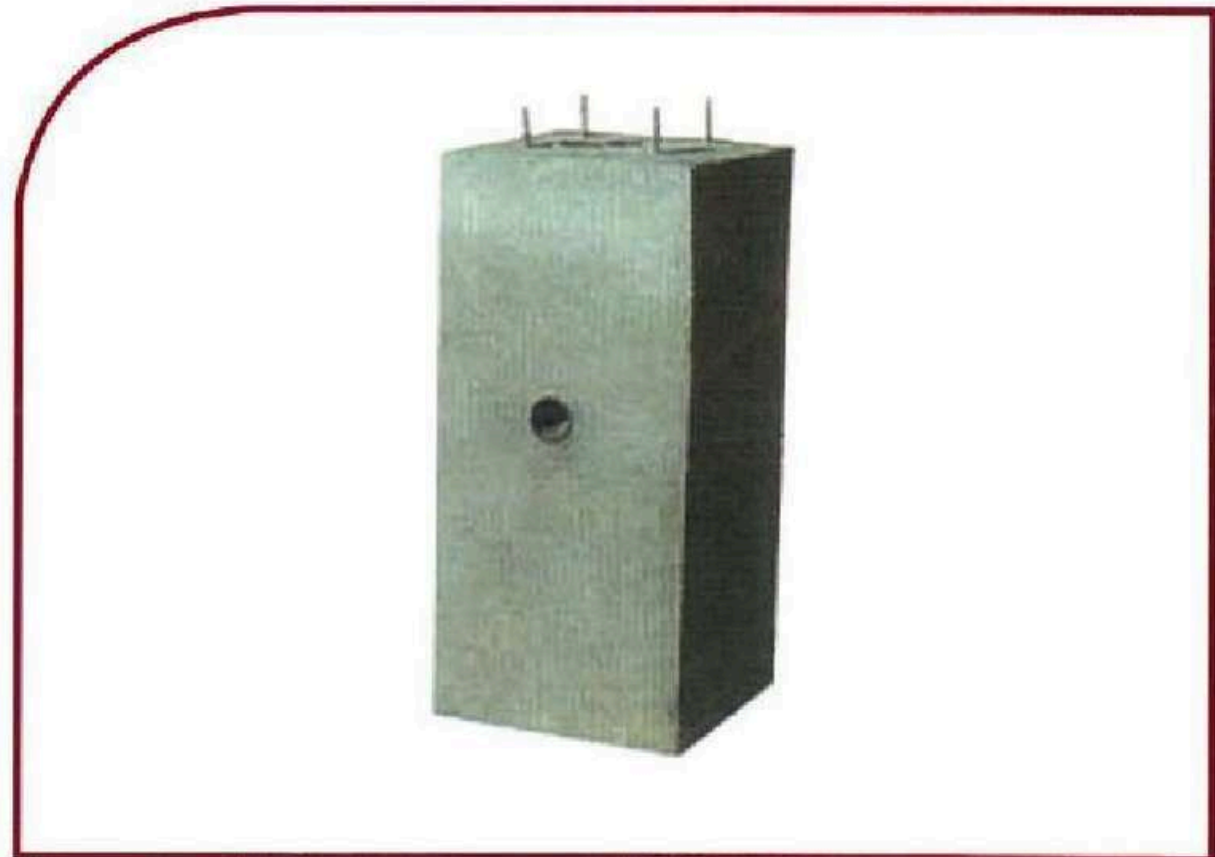

60 x 60 x 120cm

L0007

جميع المقاسات والموصفات متوفرة حسب الطلب

بريكاست

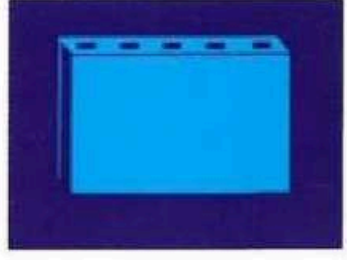

Pre - Cast



المطور المعتمد
للمقاولات

جميع المقاسات والموصفات متوفرة حسب الطلب

پریکاسٹ

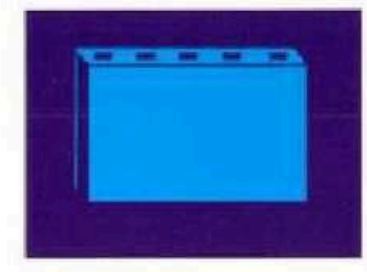

Pre - Cast

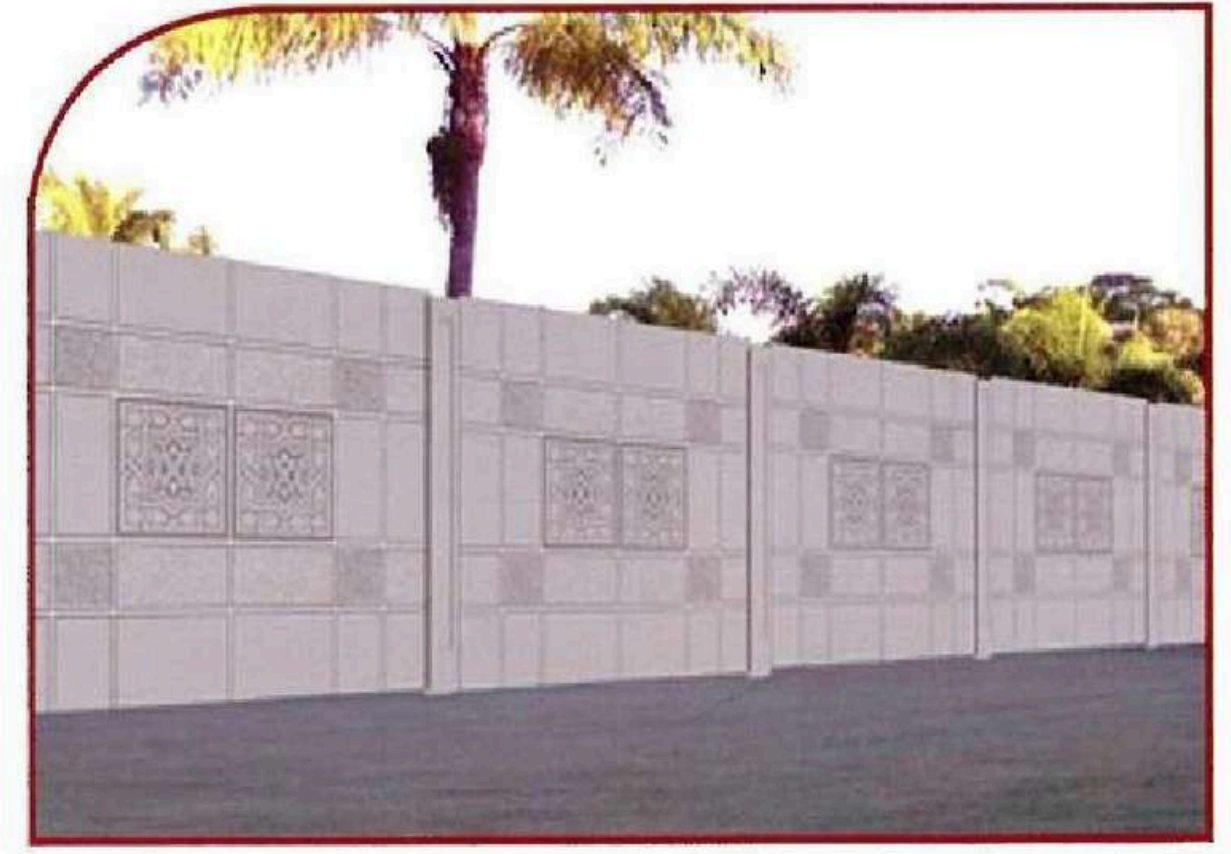
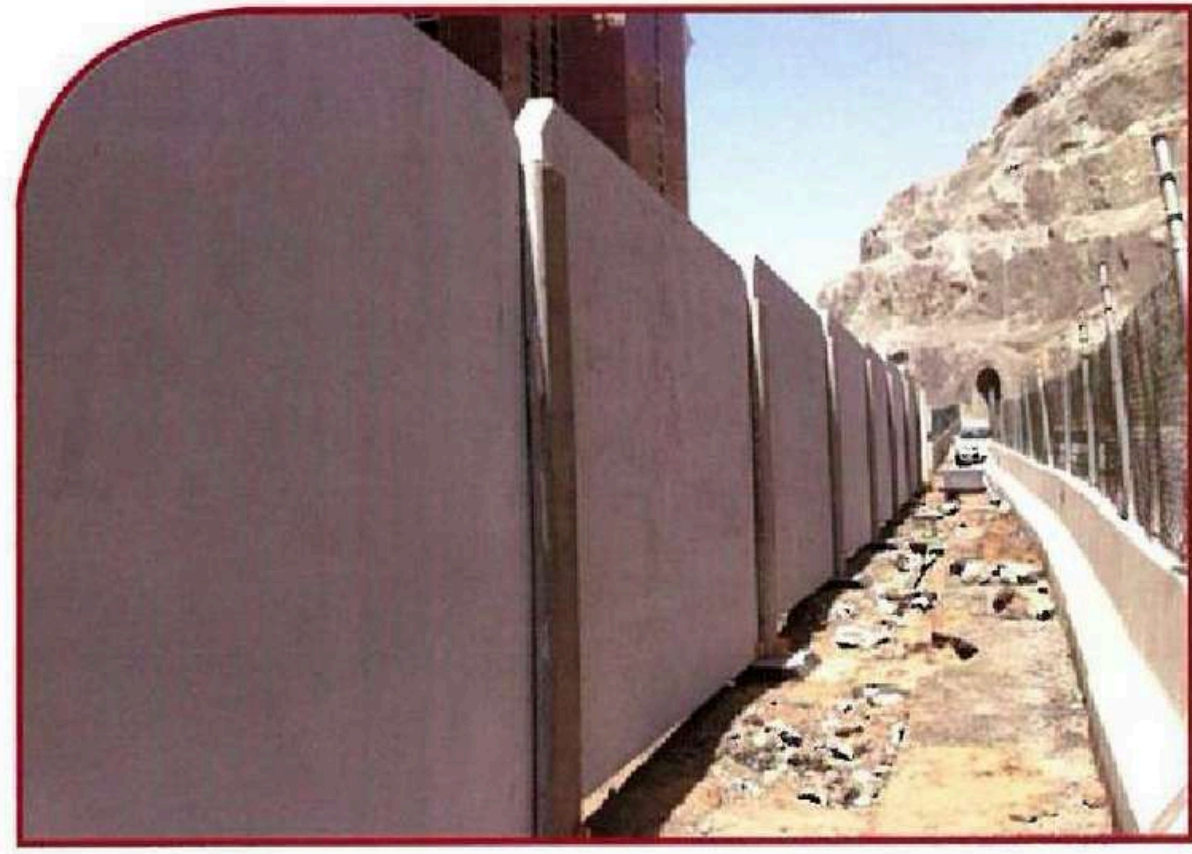

المطور المعتمد
للمقاولات

مصداات كروية



المطور المعتمد
للمقاولات

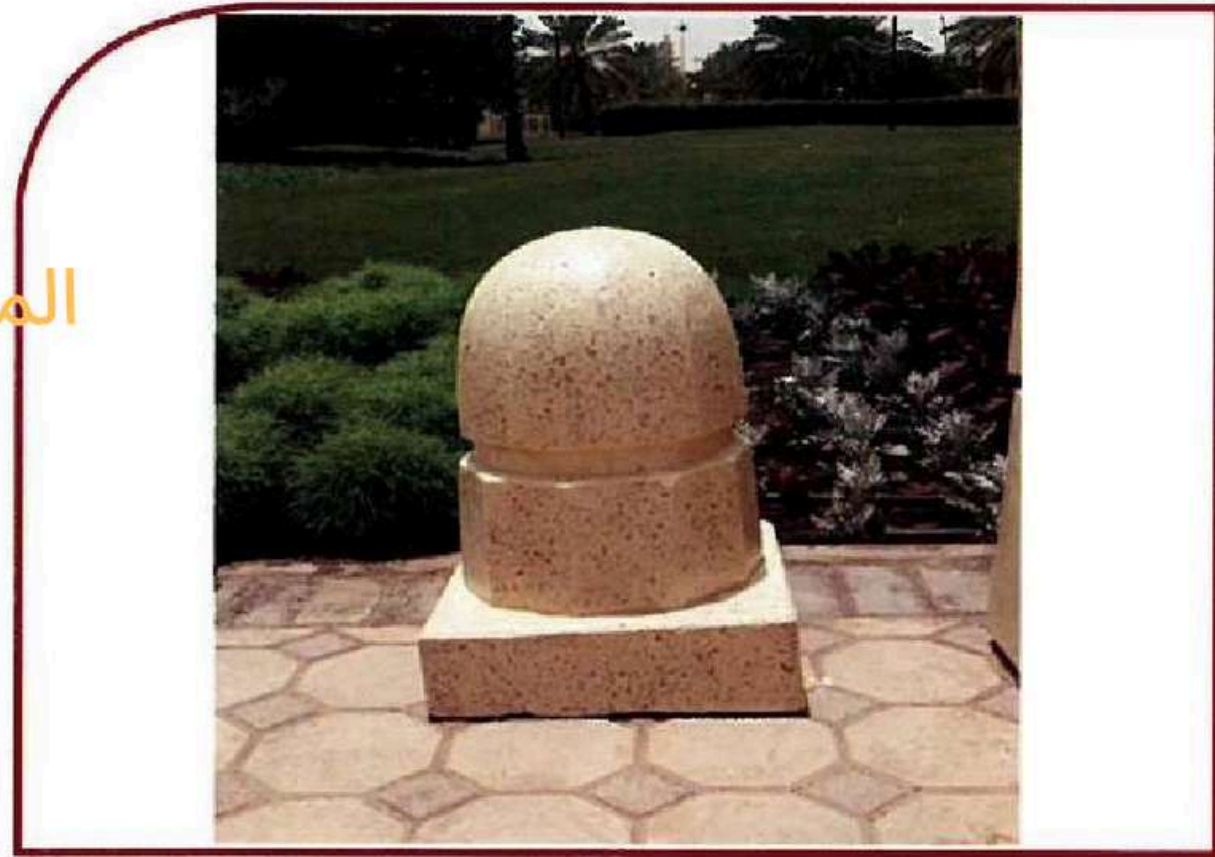

60 X 40 X 40cm

B0006

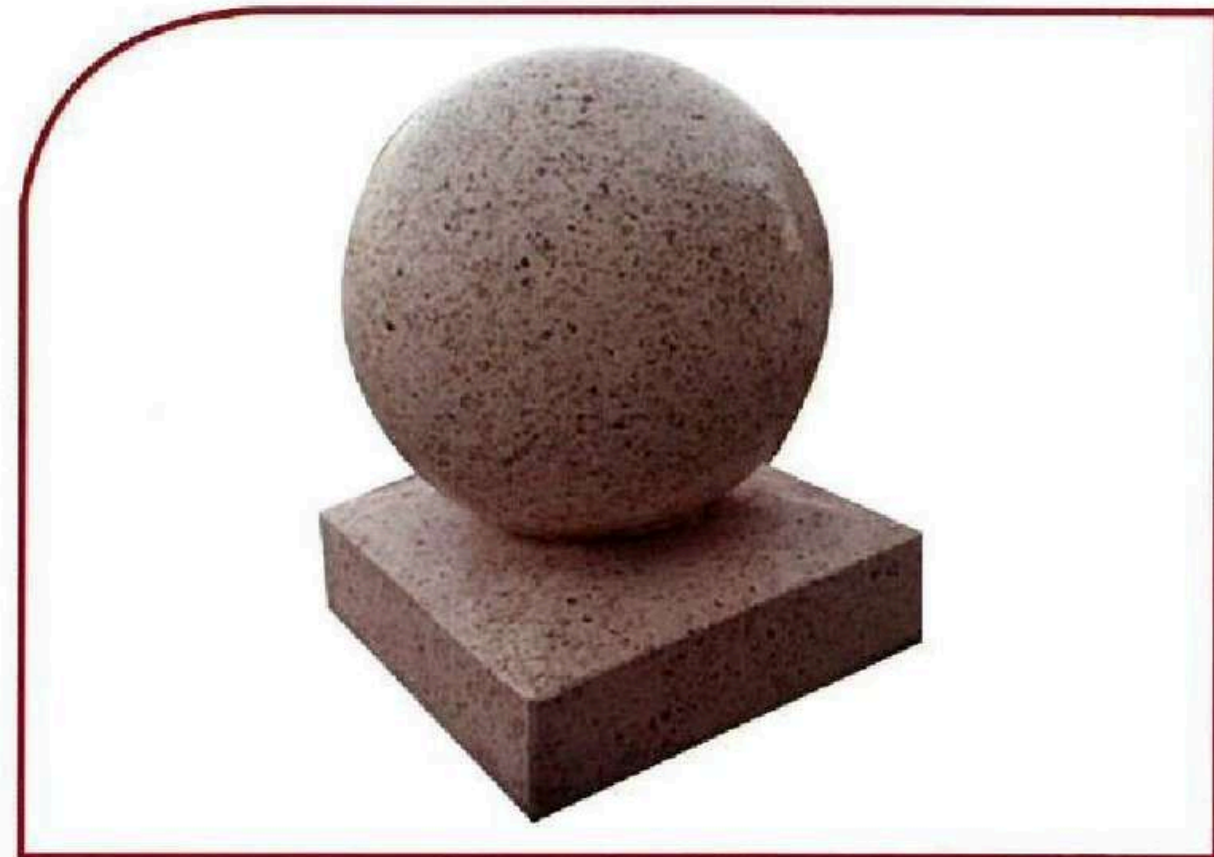

80 X 80 X 80cm

B0005



80 X 80 X 60cm

B0008



80 X 60cm

B0007

مصدات أسطوانية



المطور المعتمد
للمقاولات



40 X 60cm

B0002



45 X 65cm

B0001



40 X 40 X 60cm

B0004



50 X 60cm

B0003

بولر جميع المقاسات



المطور المعتمد
للمقاولات

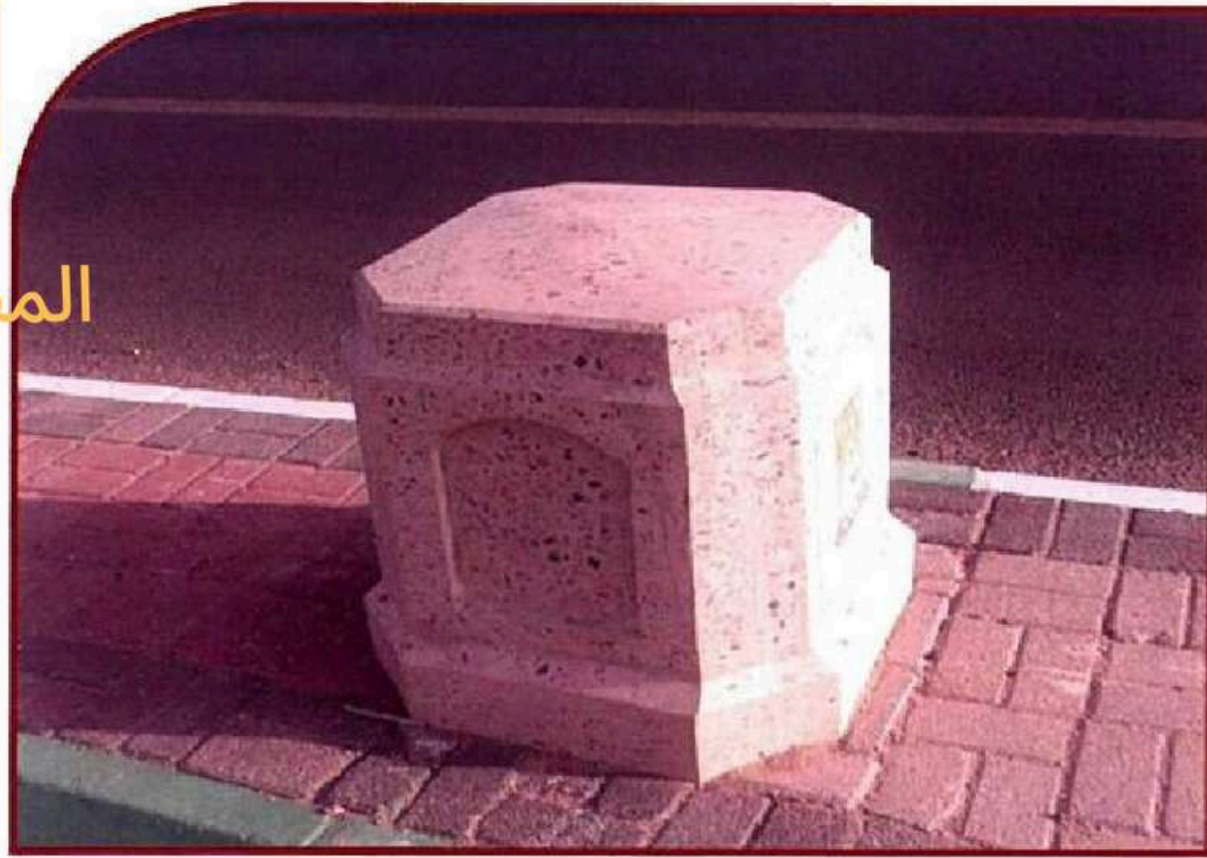

45 X 60cm

B0014



60 X 50cm

B0013



90 X 80cm

B0016



50 X 40 X 40cm

B0015

مصدات كروية / أسطوانية



المطور المعتمد
للمقاولات



55 X 40 X 40cm

B0010

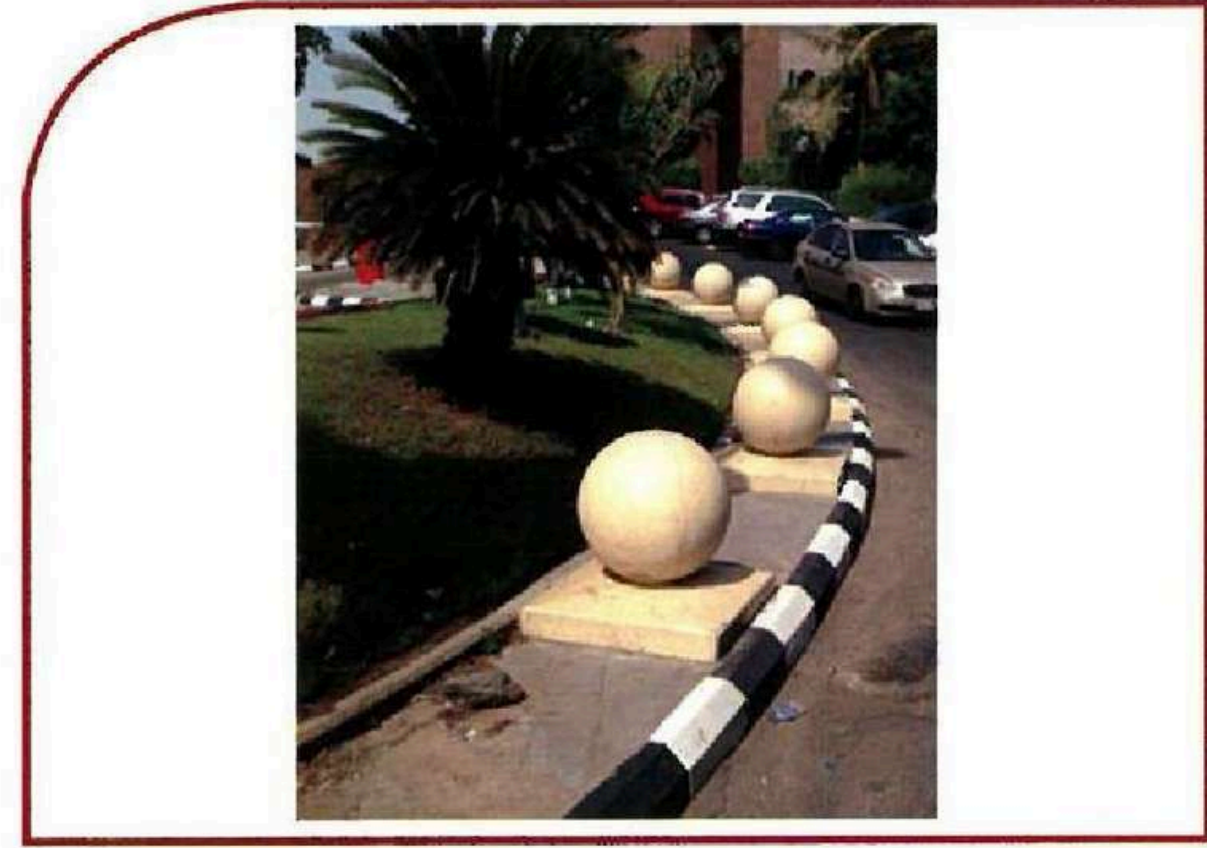

55 X 40 X 40cm

B0009



40 X 55cm

B0012



60 X 45cm

B0011

أحواض قمامة



المطور المعتمد
للمقاولات



60 x 50 x 110cm

B0018



60 X 50 x 70cm

B0017

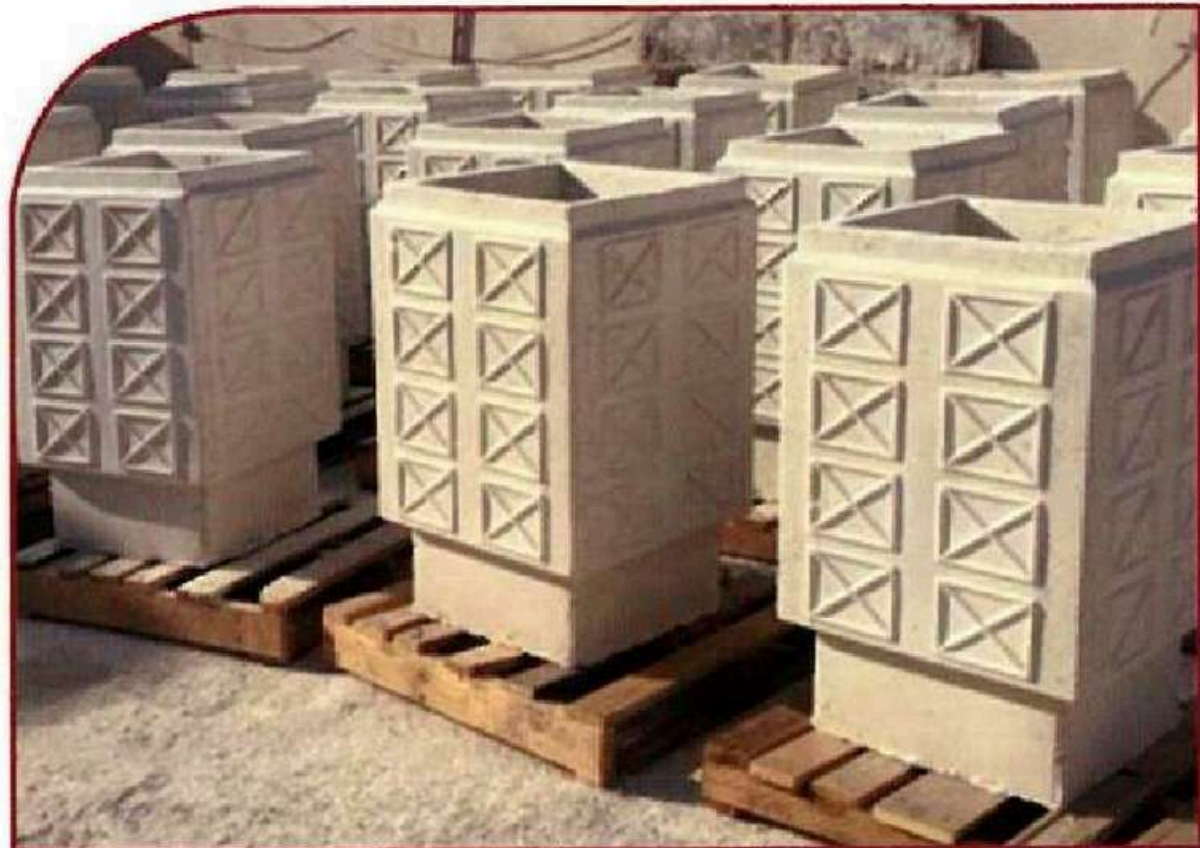

90 X 55 X 55cm

B0020

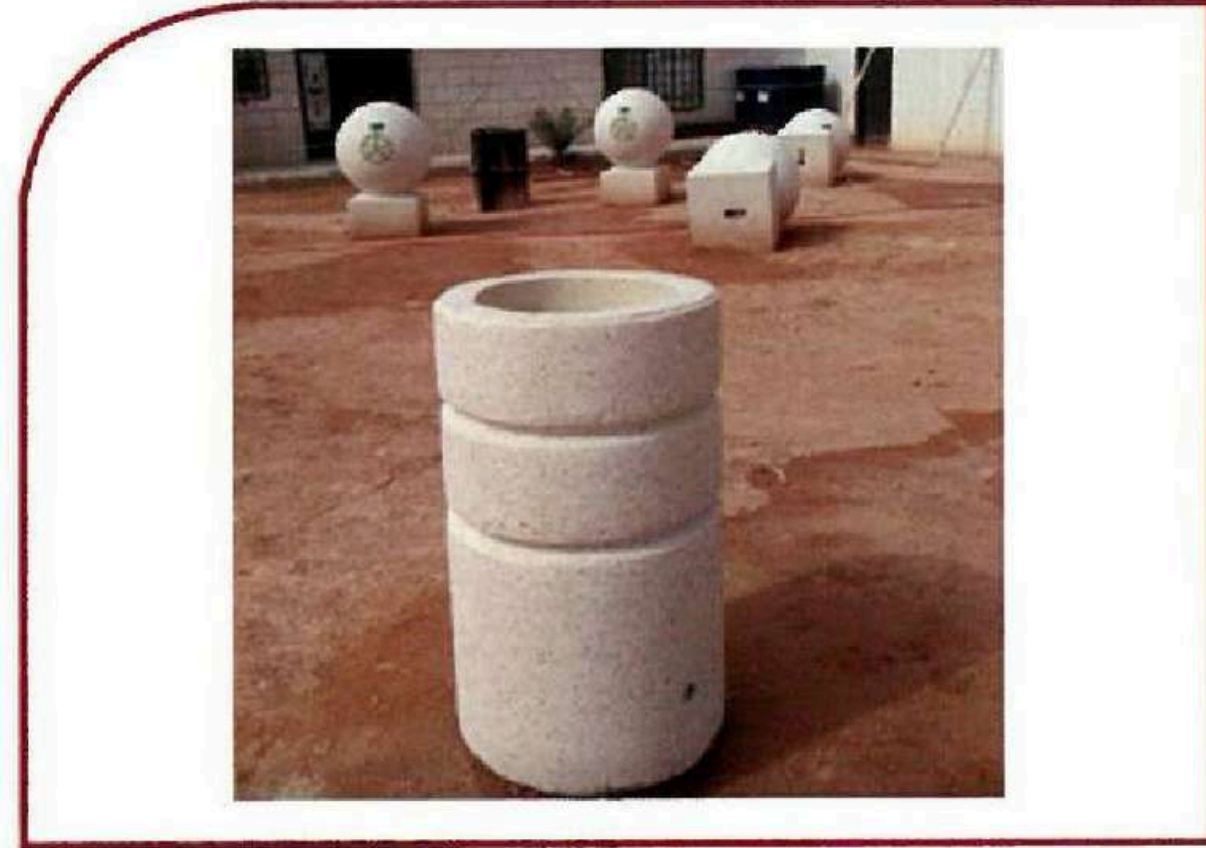

90 X 45cm

B0019

مناظر تجميلية



المطور المعتمد
للمقاولات



B0022



B0021



B0024



B0023

احواض زهور



المطور المعتمد
للمقاولات



200 X 90 X 80cm

A0002



150 X 90 X 120cm

A0001

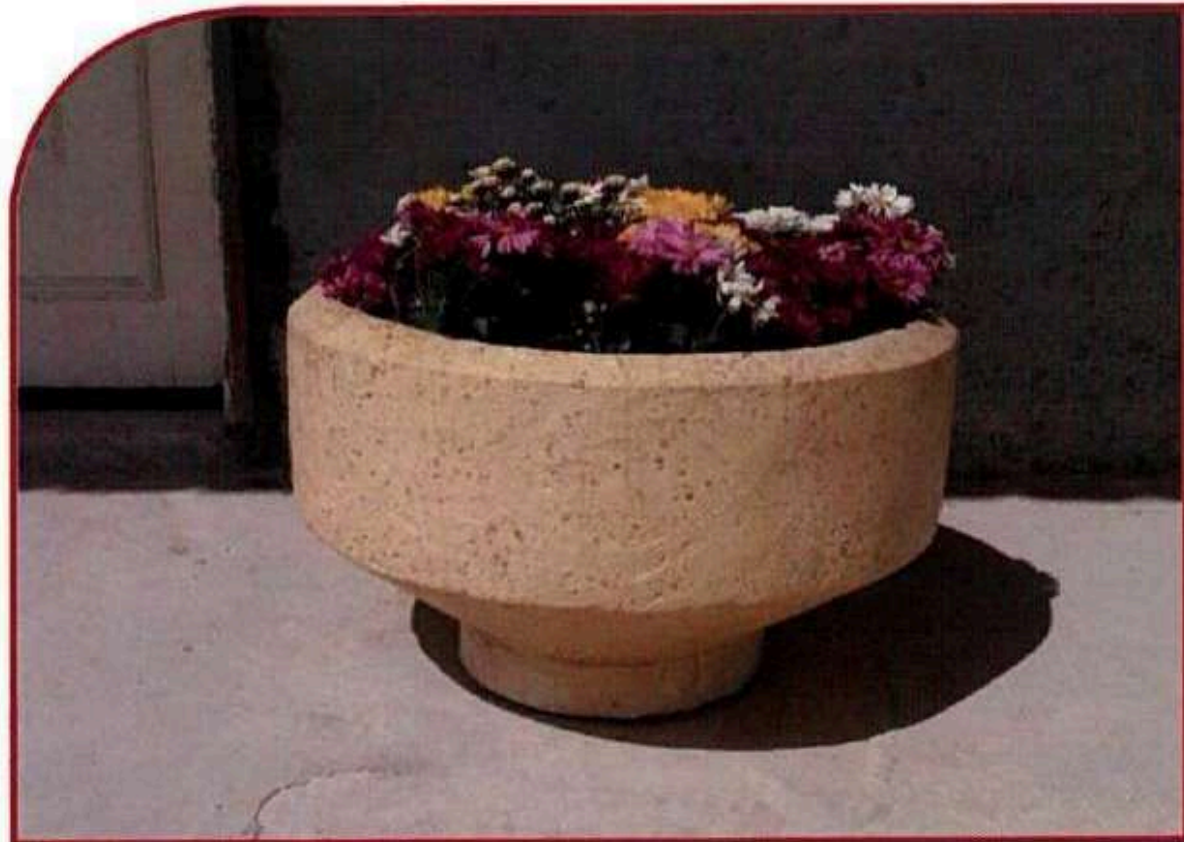

70 X 40cm

A0004



70 X 63cm

A0003

احواض زهور



المطور المعتمد
للمقاولات

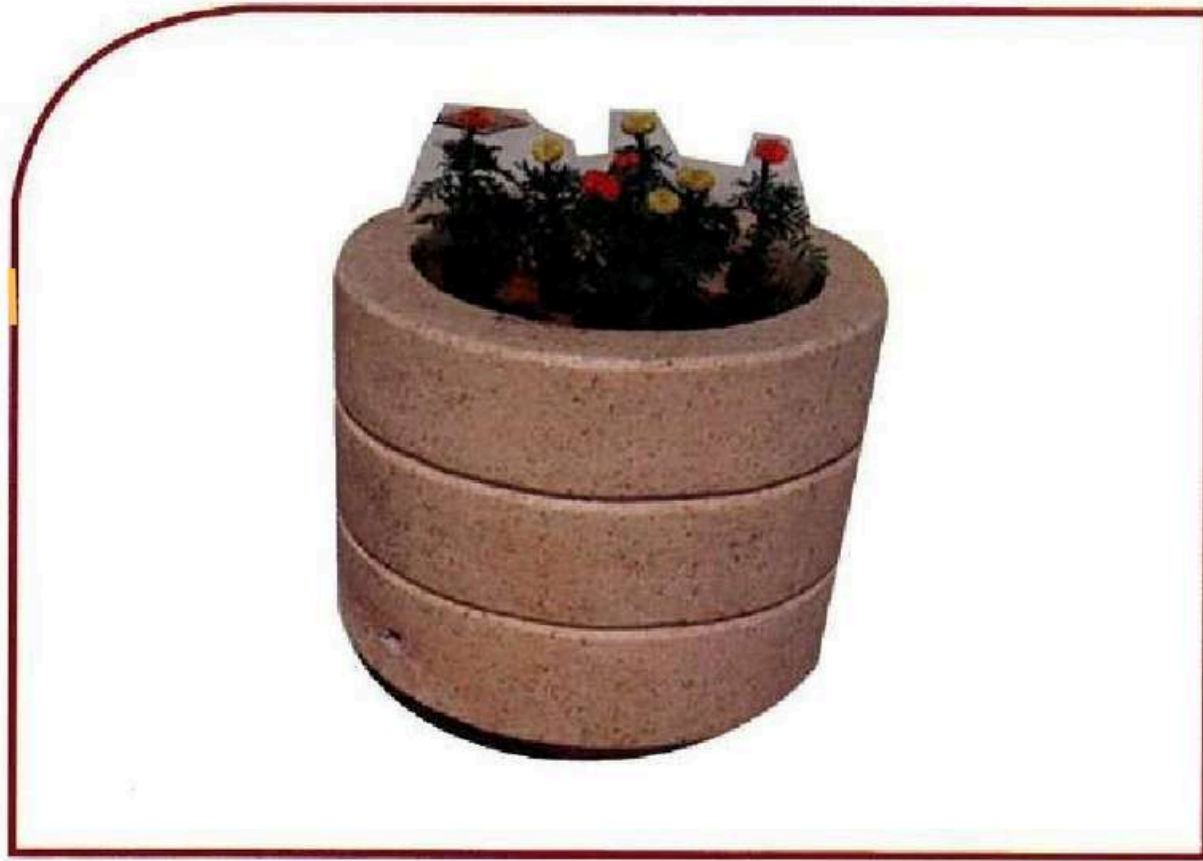

80 x 70cm

A0006



150 x 70 x 70cm

A0005



120 x 60 x 60cm

A0008



140 x 70 x 70cm

A0007

مقاعد خرسانية



المطور المعتمد
للمقاولات



180 X 50 X 90cm

S0006



180 X 50 X 50cm

S0005



200 X 50 X 50cm

S0008



200 X 50 X 90cm

S0007

مقاعد خرسانية



المطور المعتمد
للمقاولات



200 X 50 X 90cm

S0002



160 X 25 X 50cm

S0001



180 X 50 X 50cm

S0004



200 X 50 X 90cm

S0003



المطور المعتمد
للمقاولات





المطور المعتمد
للمقاولات

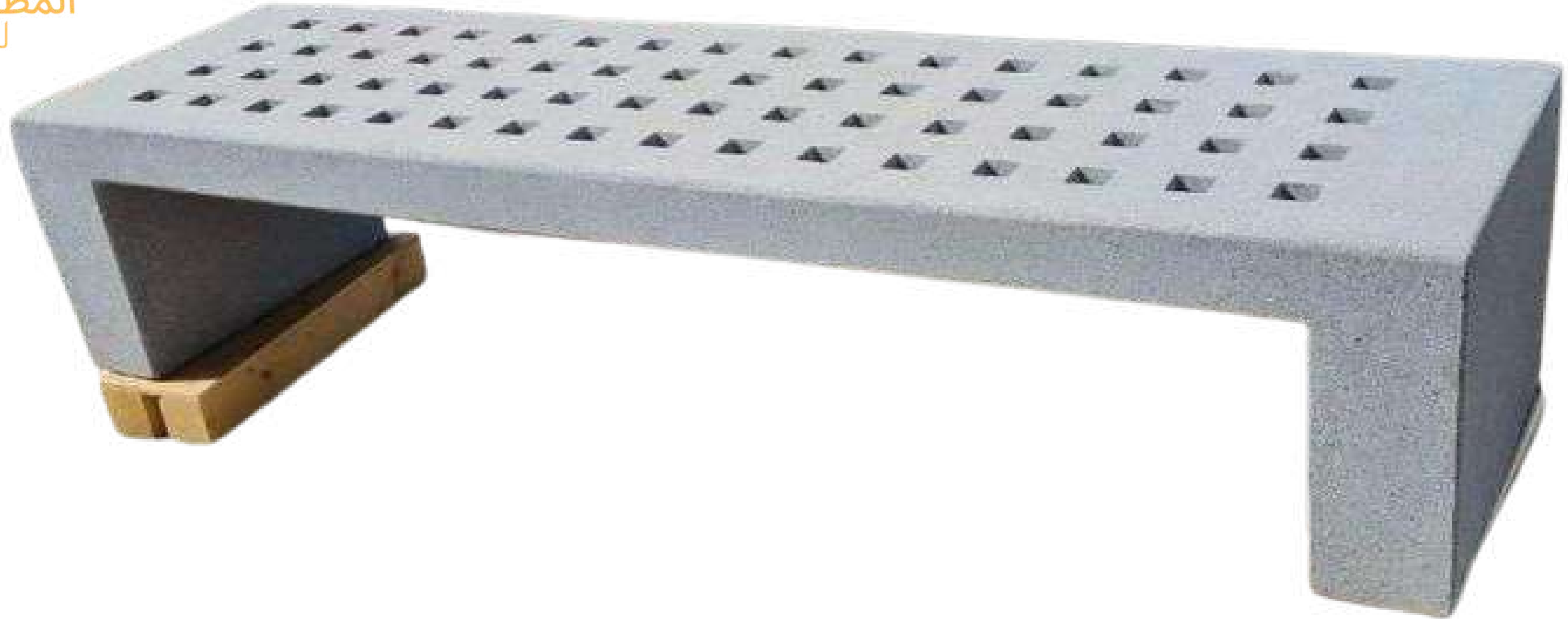



المطور المعتمد
للمقاولات

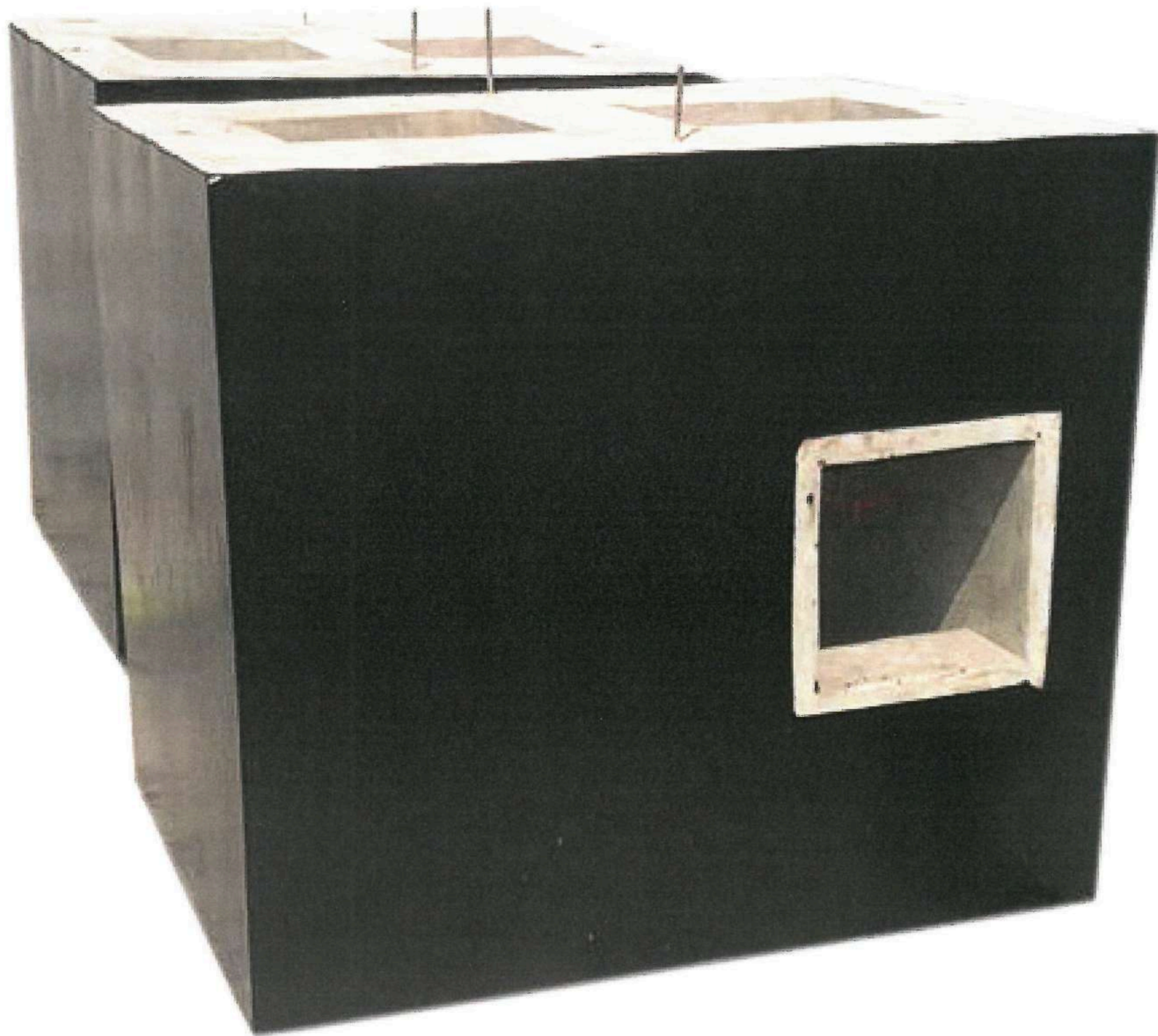



المطور المعتمد
للمقاولات

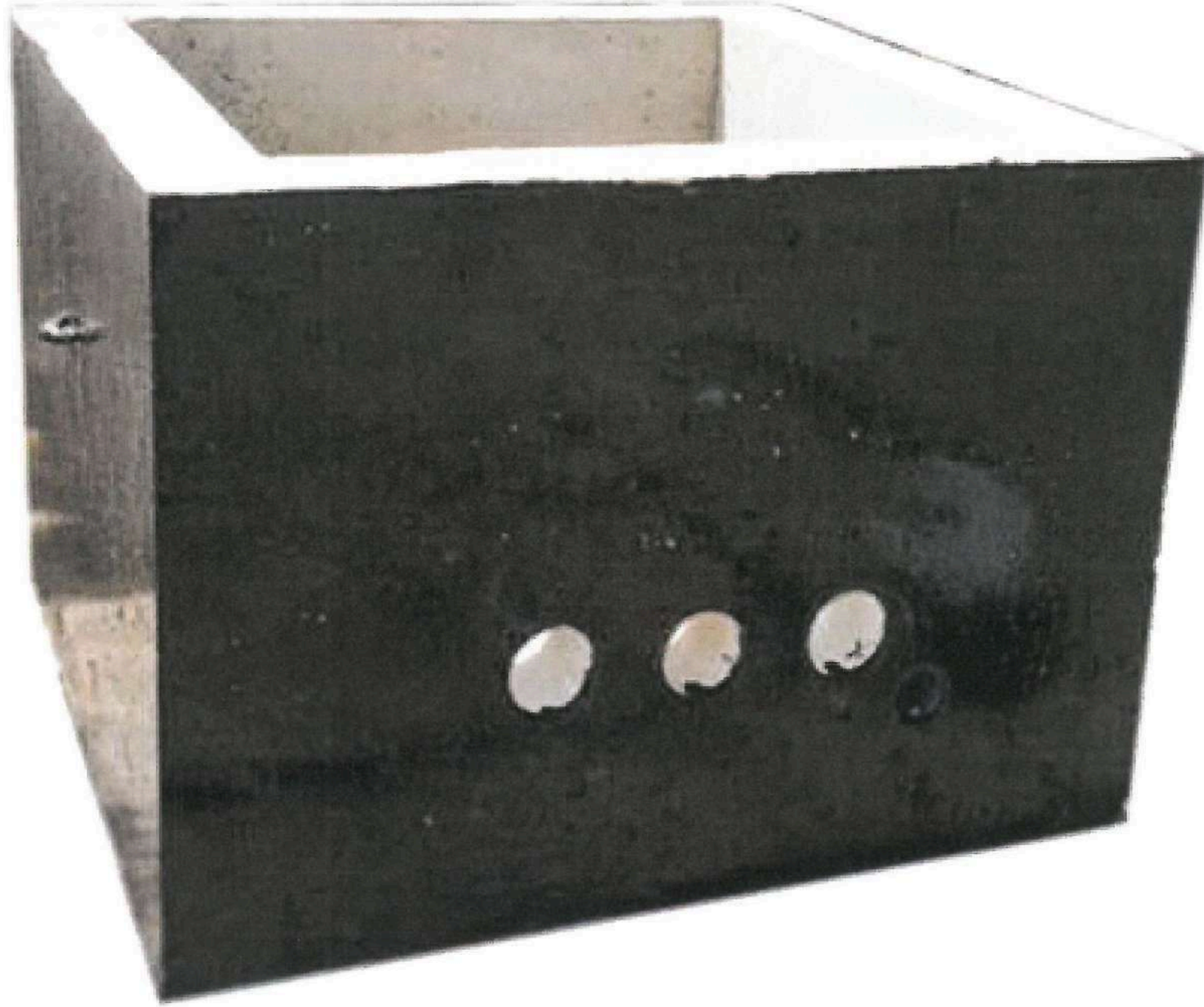



المطور المعتمد
للمقاولات

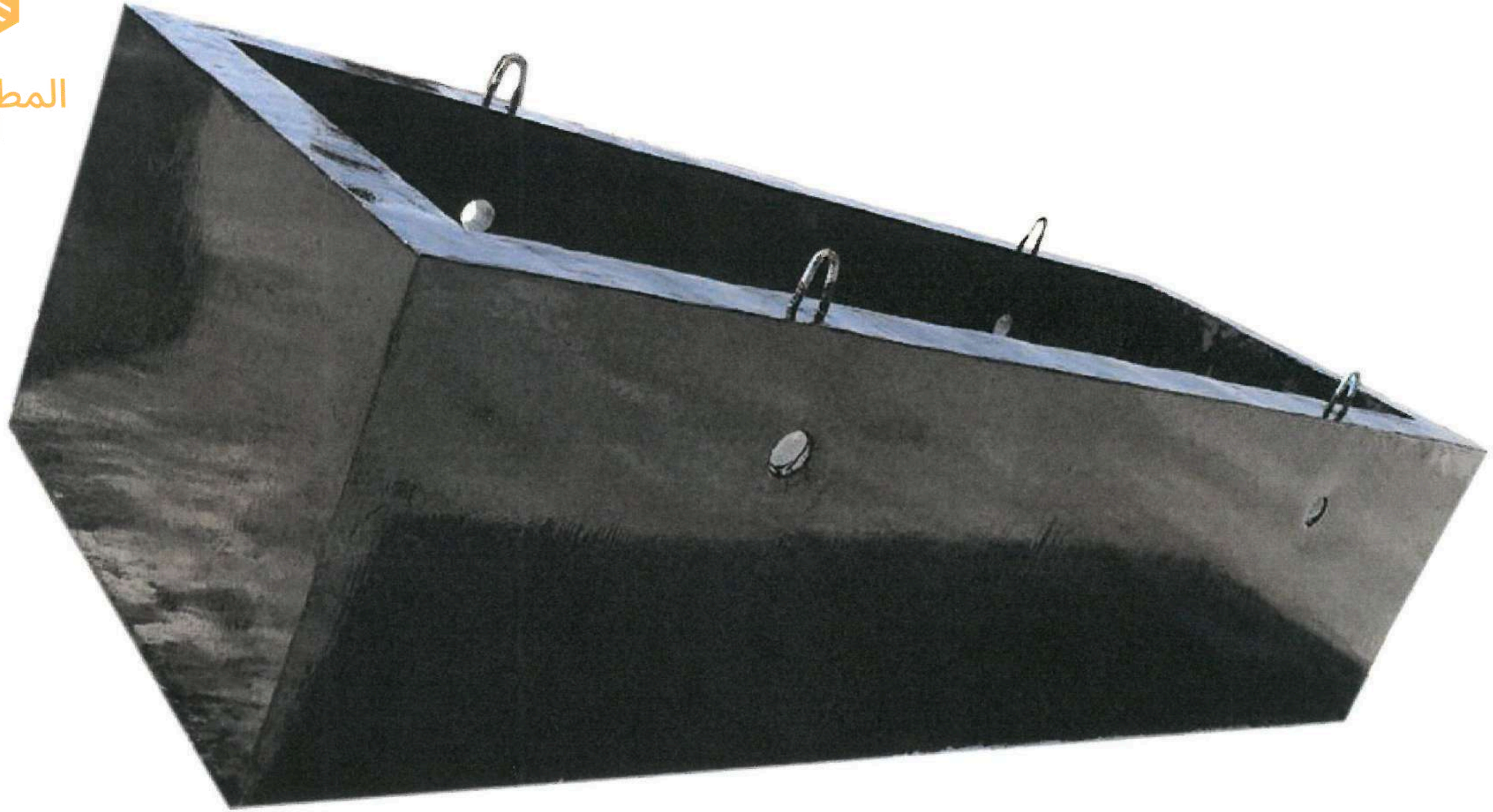



المطور المعتمد
للمقاولات





المطور المعتمد
للمقاولات

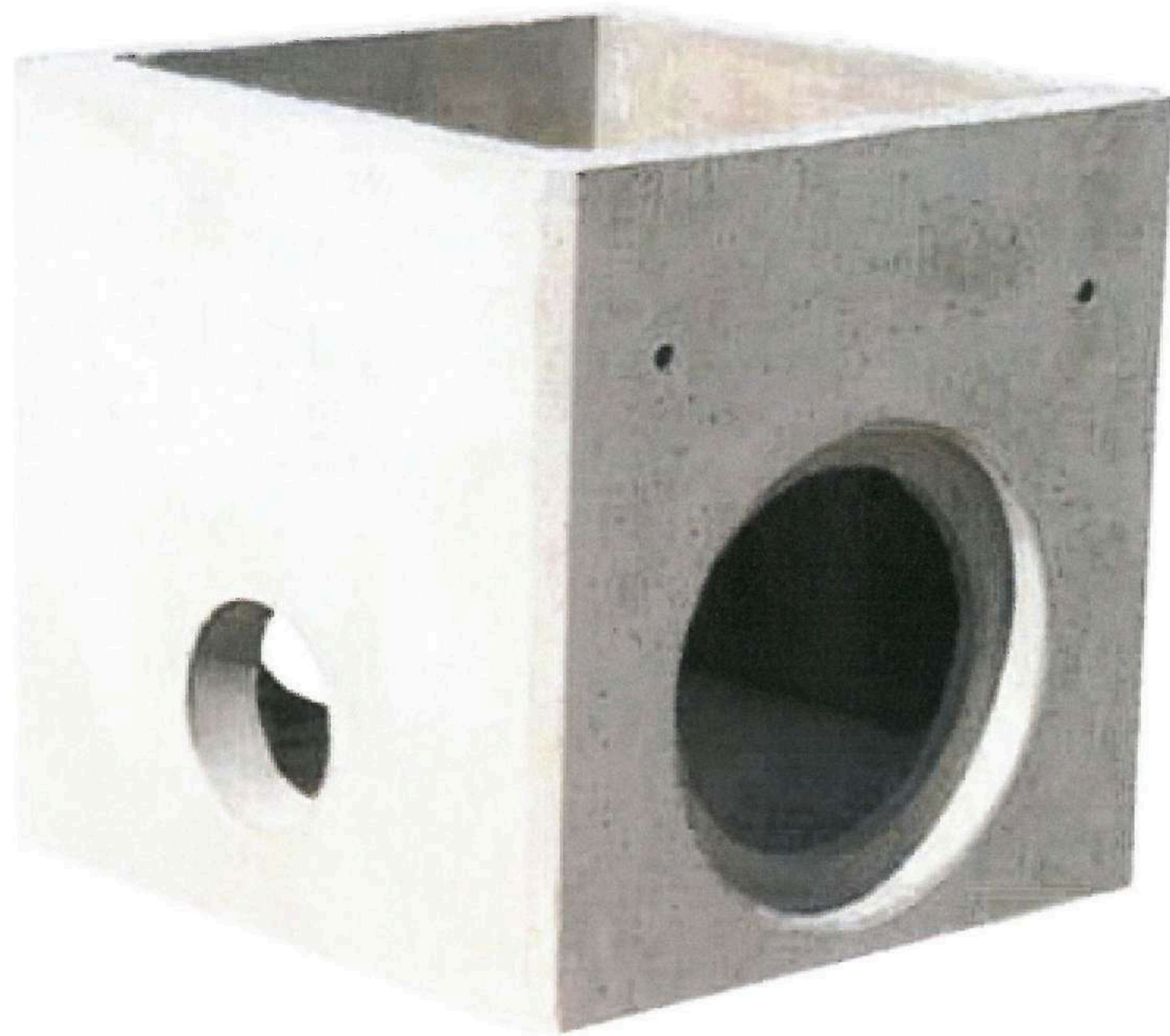



المطور المعتمد
للمقاولات

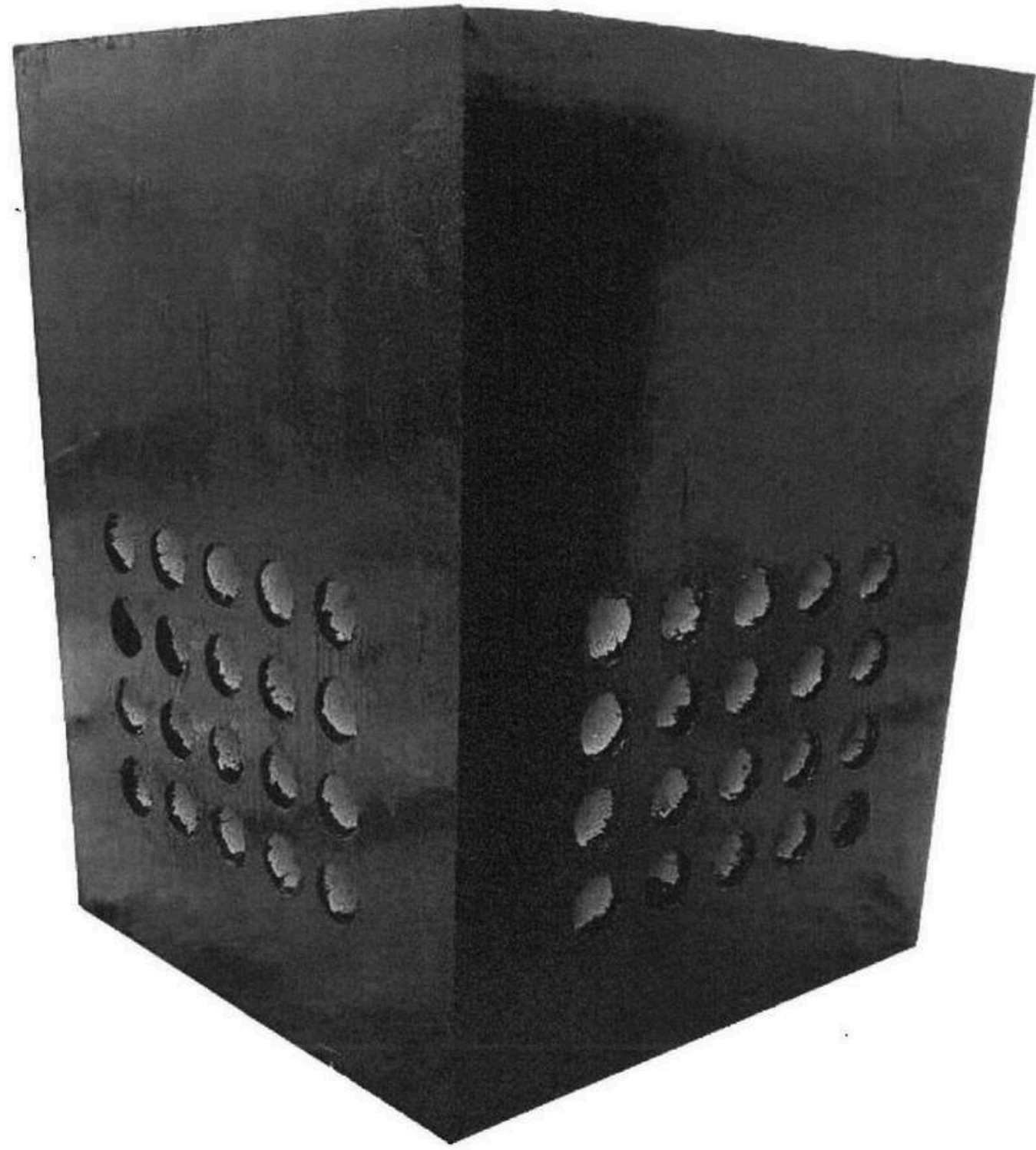



المطور المعتمد
للمقاولات





المطور المعتمد
للمقاولات



أعتماداتنا

جدير | منشآت monsha

شهادة تأهيل

تشهد الهيئة العامة للمنشآت الصغيرة والمتوسطة "منشآت" بأن
شركة المطور المعتمد للمقاولات

قد استكملت متطلبات التأهيل في خدمة جدير، وقد أعطيت هذه الشهادة بناء على طلبها دون أدنى مسؤولية،
ببب المنقح من خلال الجاركويد عن صلاحيات الشهادة حيث أنه يتم تحديثها بشكل دوري

تاريخ التأهيل: 13-Apr-2023
رقم الشهادة: 2470578740
رقم السجل التجاري: 5600106779

تعد هذه الشهادة من الوثائق الحكومية الرسمية ويمنحها نظاماً تقنياً متطوراً أو إلكترونياً أي تحديثات فورية، كما تعرض صاحبها إلى المخاطرة المالية أمام الجهات المختصة وتعتبر الامة في حال وجود أي كسب أو تعديل، دون أدنى مسؤولية على منشآت وما يرتب من ذلك، وتتغير منشآت غير مسؤولة عن أي آثار مرتبطة على الشهادة أو أي عملية تعديل أو تغيير على البيانات الواردة فيها

وزارة التجارة Ministry of Commerce

شهادة السجل التجاري

شركة المطور المعتمد للمقاولات

الرقم الوطني الموحد: 7023838886
تاريخ الإصدار: 29/06/2021
نوع الكيان: شركة ذات مسؤولية محدودة
صفات الشركة: (شخص واحد)
حالة السجل: نشط

البيانات الأساسية للسجل التجاري

7023838886

190 mc.gov.sa

SCA الهيئة السعودية للمقاولين Saudi Contractors Authority

شهادة عضوية مقاول

تاريخ الإصدار: 21 July 2024

طبقاً لتنظيم الهيئة السعودية للمقاولين فإننا نشهد بأن
مؤسسة المطور المعتمد للمقاولات
رقم العضوية: 479247929
مسجل في عضوية الهيئة حسب الإجراءات المتبعة و قد أعطى هذه الشهادة بناء على ذلك

تاريخ نهاية العضوية 21 July 2025
الرجاء التحقق من صحة وصلاحيات الشهادة عبر زيارة الرابط <https://monsha.org>

UNIVERSAL CERTIFICATION SERVICES PRIVATE LIMITED

CERTIFICATE

This is to Certify that the Management System of
AL-MOTAWAR AL-MUTAMID FOR CONTRACTING (SAUDI ARABIA MAKKA- JEDDAH-ALNAHDAH - 23523,
Has been assessed and found to be in compliance with the requirements of the standard
ISO 9001:2015
Quality Management System

شهادة تأهيل مطور عقاري

وزارة الشؤون البلدية والقروية والإسكان

رقم الشهادة: 215723476
تاريخه: 2022/01/09

تم منح شهادة تأهيل مطور عقاري
شركة المطور المعتمد للمقاولات
لاجتيازه معايير التأهيل المعتمدة *

215723476

تم منح هذه الشهادة للتسجيل والتأهيل لإعفاء التوريدات العقارية بموجب الأمر الملكي رقم 84/هـ

شهادة تصنيف مقدمي خدمات المدن

تمنح وزارة الشؤون البلدية والقروية والإسكان شهادة تصنيف بالدرجة للمشار

شركة المطور المعتمد للمقاولات

رقم الوطني الموحد / الترخيص	تاريخ إصدار السجل التجاري / الترخيص	اسم مالك المنشأة	نوع المنشأة	حسبة المنشأة
7023838886	29/06/2021	توفيق بن عبدالله مجنوع	نات مسؤولية محدودة	سعودي

رقم الشهادة	تاريخ الإصدار	درجة التقييم الإجمالي	درجة الاعتماد
2024007840	27/07/2024	اعتماد	اعتماد

المجال	النشاط
التشييد والبناء	التخصص من مياه المجاري تشغيل شبكات ومراقب معالجة الصرف الصحي تشغيل أماكن إلقاء النفايات البلدية لأغراض التصريف فيها بالإضافة إلى السكنية الإنشائية العامة للمباني غير السكنية، تشغيل (المدارس - المستشفيات، الفنادق... الخ) إنشاء المعابر والممرات والإنشاءات التي تشييد المباني الجاهزة في المواقع

تاريخ 27/07/2026 حتى تاريخ 27/07/2026
ر هذه الشهادة إلكترونياً وعلى الجهات المالكة للمشاريع التحقق من الشهادة المقدمة من خلال موقع الوزارة.

PROJECT	RED SEA VILLAGE DEVELOPMENT (RSVD)
PACKAGE	INFRASTRUCTURE (ROADS & UTILITIES TP4)
EMPLOYER	ALINMA ALTHURAYA REAL ESTATE COMPANY (AAREC)
CONSULTANT (PMC)	MORGANTI SAUDI ARABIA LTD.
ENGINEER	ARABIAN CONSULTING ENGINEERING CENTRE (ACEC)
CONTRACTOR	THABAT CONSTRUCTION COMPANY LTD. (TCC)

TP4 REQUEST FOR INSPECTION #

TP4-RFI-MV-C-021A

We request attendance to inspect the following works :

1. LOCATION:	Zone	Phase	Road/Line	From	To	Ref. Drawing # :	TP4-SD-GEN-CV-MV-1256-1268
	N/A	N/A	N/A	N/A	N/A		
	Manhole #	Chamber # / Others		Diameter		Ref. BOQ :	Bill No. 10
			N/A	N/A			

2. TYPE OF WORKS:

Utilities	Sewer <input type="checkbox"/> SW	Drain <input type="checkbox"/> DW	Potable <input type="checkbox"/> PW	Irrigation <input type="checkbox"/> IW	Electrical <input type="checkbox"/> LV	Electrical <input checked="" type="checkbox"/> MV	Roads <input type="checkbox"/> RD	Street Light <input type="checkbox"/> SL	Telecom <input type="checkbox"/> TC	Others <input type="checkbox"/>
Work Nature	Civil (C) <input checked="" type="checkbox"/>		Mechanical (M) <input type="checkbox"/>		Electrical (E) <input type="checkbox"/>		Others (O) <input type="checkbox"/>			

3. INSPECTION DATE: 26-Sep-2022 (Monday) **INSPECTION TIME:** 9:00 AM

4. INSPECTION: First Second Third

5. PURPOSE OF THE INSPECTION:

Inspection of sample foundation of RMU/USS precast foundation sample- Casted & Framework (2 Nos) in Allen Najd factory

Road/Line between N/A Phase N/A



For the Contractor

Name: Mughtan Ahmed

Signature: _____ Date: 24/Sep/22

Received for the Consultant

Name: Obada Mohammad

Signature: _____ Date: _____

6. INSPECTION REPORT:

Civil INSPECTOR: any material coming on site shall be comply with approved shop drawing.

Sign & Date

29/9/22

SURVEYOR: _____

ENGINEER: _____

RESIDENT ENGINEER: _____

Inspection Status (*) (A) (B) (C) (D)

Date of Inspection 29 / 9 / 22 Time of Inspection: 12 hr 00 m

For the Consultant

Name: Bassam Shafei

Signature: _____ Date: 03/10/2022







Received for the Contractor

Name: Sheikh Mohamad Reza

Signature: _____ Date: _____

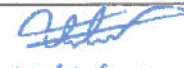
(*): (A): Approved (B): Approved as noted (C): Revise & resubmit (D): Rejected

ATTACHED ARE ALL RELEVANT TESTS & DRAWINGS.

PROJECT	RED SEA VILLAGE DEVELOPMENT (RSVD)									
PACKAGE	INFRASTRUCTURE (ROADS & UTILITIES TP4)									
EMPLOYER	ALINMA ALTHURAYA REAL ESTATE COMPANY (AAREC)									
CONSULTANT (PM)	MORGANTI SAUDI ARABIA LTD.									
ENGINEER	ARABIAN CONSULTING ENGINEERING CENTRE (ACEC)									
CONTRACTOR	THABAT CONSTRUCTION COMPANY LTD. (TCC)									
TP4 REQUEST FOR INSPECTION #								TP4-RFI-MV-C-021		
We request attendance to inspect the following works :										
1. LOCATION:	Zone	Phase	Road/Line	From	To	Ref. Drawing # :		TP4-SD-GEN-CV-MV-1256-1268		
	N/A	N/A	N/A	N/A	N/A					
	Manhole #	Chamber # / Others		Diameter		Ref. BOQ :		Bill No. 10		
			N/A	N/A						
2. TYPE OF WORKS:										
Utilities	Sewer <input type="checkbox"/> SW	Drain <input type="checkbox"/> DW	Potable <input type="checkbox"/> PW	Irrigation <input type="checkbox"/> IW	Electrical <input type="checkbox"/> LV	Electrical <input checked="" type="checkbox"/> MV	Roads <input type="checkbox"/> RD	Street Light <input type="checkbox"/> SL	Telecom <input type="checkbox"/> TC	Others <input type="checkbox"/>
Work Nature	Civil (C) <input checked="" type="checkbox"/>		Mechanical (M) <input type="checkbox"/>		Electrical (E) <input type="checkbox"/>		Others (O) <input type="checkbox"/>			
3. INSPECTION DATE: 04-Sep-2022 (Sunday)						INSPECTION TIME: 9:00 AM				
4. INSPECTION: <input checked="" type="checkbox"/> First <input type="checkbox"/> Second <input type="checkbox"/> Third										
5. PURPOSE OF THE INSPECTION:										
Inspection of sample foundation of RMU/USS precast foundation sample- Casted & Framework in Allen Najd factory Road/Line etwee N/A Phase N/A										
For the Contractor					Received for the Consultant					
Name: Abdulrahman Shareif					Name: M.Hasnain Ishfaq					
Signature:  Date: 01/Sep/22					Signature:  Date: 					
6. INSPECTION REPORT:										Sign & Date
<input checked="" type="checkbox"/> Civil INSPECTOR Sample Not comply with approved shop drawing										 4/9/22
<input type="checkbox"/> SURVEYOR										
<input type="checkbox"/> ENGINEER:										
<input type="checkbox"/> RESIDENT ENGINEER										
Inspection Status (*) (A) <input type="checkbox"/> (B) <input type="checkbox"/> (C) <input checked="" type="checkbox"/> (D) <input type="checkbox"/>										
Date of Inspection 4 / 9 / 22						Time of Inspection: 2 hr 00 m				
For the Consultant					Received for the Contractor					
Name: Bassam Shafei 05/09/2022					Name: Sheikh Mohamad Reza					
Signature:  Date: 05/09/2022					Signature:  Date:  					

(*): (A): Approved (B): Approved as noted (C): Revise & resubmit (D): Rejected

COMMENT SHEETS

PROJECT	CONTRACT	OWNER	CONTRACTOR
Jeddah Stormwater Drainage (JSWD)	SUBNET D006/UP03	Jeddah Municipality	Civil & Electrical Projects Contracting Company

Consultant's Comments on Submittal Document No. JSW-CP-SNET-PRQ-CI-0038
For Prequalification of M/s ALREEN.

1. M/s AL-REEN is temporarily approved, as Supplier for Manhole, CB & PRD.
2. Test Certificates shall be provided and Engineer to Witness Calibration Tests.
3. For Documentation purposes, Contractor has to check completeness of Required Documents as shown on table below

SN	DOCUMENTATION CHECKLIST		REMARKS
1	Company Profile	<input checked="" type="checkbox"/>	
2	List of Materials Supplied	<input checked="" type="checkbox"/>	
3	Organizational Chart	<input checked="" type="checkbox"/>	
4	Commercial Documents	<input checked="" type="checkbox"/>	
5	ISO Certifications	<input type="checkbox"/>	NA
6	SASO Certifications	<input type="checkbox"/>	NA
7	List of Machineries and Equipment (Supported with valid 3 rd Party Calibration Certificate)	<input type="checkbox"/>	NA
8	Previous Approvals	<input checked="" type="checkbox"/>	
9	Completed Project References	<input type="checkbox"/>	NA
10	Other	<input type="checkbox"/>	

4. Contractor to consider Documentations listed above to be updated and valid and submit missing documents within 7 days upon receipt of this submittal.
5. Material Submittal shall be issued for specific material proposed for the Project.

Reviewed by:
 Name: HAMED ALKHATTABI
 Designation: Sr. QA/QC Engineer
 Signature: [Signature]

Approved by:
 Name: MEHRDAD BIRGANI-NIA
 Designation: Project Director
 Signature: [Signature]

10/4/2019



Jeddah Municipality



Louis Berger



SUBMITTAL FORM

Submittal No.: JSW-CP-SNET- PRQ-CI-0038

Rev. No.:

PROJECT	CONTRACT	OWNER	CONTRACTOR
Jeddah Stormwater Drainage (JSWD)	SUBNET D006/UP03	Jeddah Municipality	Civil & Electrical Projects Contracting Company.

Subject: Pre-Qualification for AL-AREEN (MANHOLE, CB & PRD)

Specs. Code & Ref.: BOQ Code Ref. Drawing No.: Date Received:
 Date Returned:

Sub-Contractor

Name: Phone:
 Address:

Manufacturer **Supplier / Agent**
 Name: AI-AREEN Name:
 Address: Jeddah Address:
 Phone: 012/6073989 Phone:



Information Submitted and Attached:

- | | |
|---|---|
| <input type="checkbox"/> Certificates | <input type="checkbox"/> Operation & Maintenance Manual |
| <input type="checkbox"/> Technical Brochure | <input type="checkbox"/> Spare Parts List |
| <input type="checkbox"/> Manufacturer's Data & Specs. | <input type="checkbox"/> As-Built Drawings |
| <input type="checkbox"/> Shop Drawings | <input type="checkbox"/> Warranty |
| <input type="checkbox"/> Samples | <input type="checkbox"/> Others (specify): |



Contractor Comments: For Review and Approval

See Attachment

Note: This review does not relieve the Contractor of his responsibilities under the terms of the Contract nor authorizes additional compensation.

Name: **Engr. Yousef Mahmoud Shaeira**
 Signature:
 Date: 11/4/2019

Consultant Comments:

Final approval subjected to Manhole, PRD, CB samples

See Attachment

Status:	Discipline	Louis Berger Engineer	Louis Berger Project Director
<input type="checkbox"/> A: Approved <input checked="" type="checkbox"/> B: Temporary Approved <input type="checkbox"/> C: Revise and Resubmit <input type="checkbox"/> D: Rejected <input type="checkbox"/> I: For Information	<input type="checkbox"/> Geotechnical <input type="checkbox"/> Architectural <input type="checkbox"/> Civil / Structural <input type="checkbox"/> Mechanical <input type="checkbox"/> Electrical <input type="checkbox"/> HSE	Name: <i>Hamad Alkhoraji</i> Signature: Date: 11 Apr 2019	Name: <i>M. S. Singari</i> Signature: Date:

JAZECOAT-EPS

**2-Component, Non Toxic, Solvent free Highly Chemical & Impact Resistance
Epoxy resin modified with Polysulphide Flexible Protective Coating for STP works.**

Product Description

JAZECOAT – EPS is 2-component, solvent-free (100% solid), non-toxic, epoxy resin-based modified with polysulfide resins, high-build, high performance, flexible, highly chemical resistant protective coating for STP works. It will provide after application and curing a durable protective, sealing & decorative film with an excellent impact & chemical resistance that is easy to-clean surface finish. It is based on selected epoxy and polysulfide resins & special hardener that resist amine blush. The product is available in standard colours or any colour upon request.

Uses

JAZECOAT– EPS is formulated to provide continuous protective coating having highly chemical & impact resistant properties. It is formulated for lining and waterproofing water retaining structures and water treatment plants, sewage concrete and metal pipes. It is suitable for areas where thick film is required such as:

- Water tanks & reservoirs and silos.
- Food processing areas.
- Concrete & steel pipes
- Oil refineries.
- Paper mills.
- Laboratories and abattoirs.
- Sewage Treatment works
- Water treatment plants.
- Power Stations
- Garages and hangars

Advantages

- Easy to apply by suitable brush or roller.
- Solvent-free (100 % Solid), odorless, and
- Non-toxic, highly durable impact corrosion resistance.
- Excellent abrasion and resistance.
- Can be applied on dry and damp concrete surfaces.
- Flexible and UV stable.
- Excellent adhesion to sound concrete & masonry substrates.

Highly chemical resistant to most common chemical reagents in sewage works. Can be used with glass fiber to provide more mechanical properties. Formulated to be suitable for the Middle East Climates.

Standards

JAZECOAT- EPS complies with ASTM C- 881, Type III, Grade 2, and Class B & C

Technical Properties

Appearance	Pigmented free flowing liquid	
Specific Gravity	1.30 ± 0.05	
Volume Solids	100 %	
Service Temperature	-10 – 60 °C	
Time between Recoating	12 – 24-hours	
Pot-Life @ 25 °C	70 minutes	
Full-Cure @ 25 °C	7 Days	
Tensile Strength @ 23 °C	10.2 MPa	
Elongation at Break (ASTM D 412)	64%	
Tear Strength (ASTM D 1004)	13 N/mm ²	
Hardness (ASTM D 2240)	57 Shore D	
Bond Strength	2.5 N / mm ²	
Water Vapour Transmission rate	1.17g/m ² /day	
Abrasion Resistance	100 cycles 10-15 mg 500 cycles 60-70 mg	
(ASTM D 1044-90, CS-17Wheel500g)		
Static Crack Bridging Capability	1.1 mm	
U V Resistance	Pass	
Effect on Water BS 6920	Pass	

Chemical Resistance



JAZECOAT – EPS has been tested for chemical resistance to a comprehensive range of industrial & domestic chemicals. After constant immersion for 90-days @ 35 °C in accordance with ASTM D-2240 (Shore D hardness), the results are:

Acids

Hydrochloric	25 %	Excellent
Sulfuric	25 %	Excellent
Nitric	25 %	Good
Acetic	10 %	Excellent
Lactic	10 %	Excellent
Citric	10 %	Excellent

Alkalis

Sodium hydroxide 25 %	Excellent
Sodium Carbonate 25 %	Excellent
Ammonia 10 %	Excellent
Potassium Hydroxide 25 %	Excellent
Sodium Hypochlorite 15 %	Excellent

Solvents & Oils

Ethanol Ethyl	Excellent
Glycol White	Excellent
spirit Petrol &	Excellent
Diesel Coconut	Excellent
Oil Cotton Seed	Excellent
Oil Soya Bean	Excellent
Oil silicates	Excellent
Vegetable Oil	Excellent
Detergent Fat	Excellent
Milk Pine Oil	Excellent
Linseed Oil	Excellent
water	Excellent
	Excellent
	Excellent
	Excellent

Guidelines for Applications

Surface Preparation

All surfaces shall be sound, clean free from dust, grease & oils, curing agents & mould releasing agents or other materials may affect the bond of the product and the substrates. Steel or metal surfaces should be free from rust, scale or other contaminants.

Priming

JAZEPRIME- EP10 can be used prior to the application (See its data Sheet).

Mixing

Stir each component of JAZECOAT –EPS well before mixing. Pour Component A into the Component B and mix well for 2 -5minutes until uniform consistency & colour is achieved.

Application

Apply the mixed materials of JAZECOAT–EPS onto prepared & primed substrates using suitable brush, roller or airless spray method for large areas

Apply the second coat after application of the first coat with 12 hours.

Packaging

JAZECOAT – EPS is supplied in 5 kg and 20-Kg Kits.

Storage & Shelf-life

JAZECOAT– EPS shall be stored in normal conditions away from any extreme temperatures, Shelf – life is 24 months if stored properly.

Health & Safety

JAZECOAT – EPS non-toxic, non-corrosive, and non-dangerous.

For Ecology: Do not dispose directly to water or soil. Mix Component A with Component B and wait till hardening, then bury in landfill in accordance with the local regulations.

- Splashes on skin will be washed with water and soap.



مصنع الجازع للكيمياويات الإنشائية
JAZEA FOR CONSTRUCTION CHEMICALS
Riyadh Head Office
Tel: +966 1 4055852
4056011
Fax: +966 1 4051576

Factory
+966 1 8123947
+966 1 4159693

Dammam
+966 3 8154338
+966 3 8154337





أمانة جدة
Jeddah Municipality



Louis Berger



SUBMITTAL FORM

Submittal No.: JSW-CP-SNET- PRQ-CI-0010

Rev. No.:

PROJECT	CONTRACT	OWNER	CONTRACTOR
Jeddah Stormwater Drainage (JSWD)	SUBNET D006/UP03	Jeddah Municipality	Civil & Electrical Projects Contracting Company.

Subject: Pre-Qualification for NCPF CO. LTD (COVER FOR MANHOLE, CATCH BASIN & PRD)

Specs. Code & Ref.:	BOQ Code Ref.	Drawing No.:	Date Received: _____
			Date Returned: _____

Sub-Contractor

Name: _____ Phone: _____
Address: _____

Manufacturer

**NATIONAL CAST IRON PRODUCTS
FACTORY**

Name: _____
Address: **P.O BOX 50753, JEDDAH 21533**
Phone: **00966-12 6370496**

Supplier / Agent

Name: _____
Address: _____
Phone: _____

Information Submitted and Attached:

- | | |
|---|---|
| <input type="checkbox"/> Certificates | <input type="checkbox"/> Operation & Maintenance Manual |
| <input type="checkbox"/> Technical Brochure | <input type="checkbox"/> Spare Parts List |
| <input type="checkbox"/> Manufacturer's Data & Specs. | <input type="checkbox"/> As-Built Drawings |
| <input type="checkbox"/> Shop Drawings | <input type="checkbox"/> Warranty |
| <input type="checkbox"/> Samples | <input type="checkbox"/> Others (specify): _____ |



Contractor Comments: **For Review and Approval**

See Attachment

Note: This review does not relieve the Contractor of his responsibilities under the terms of the Contract nor authorizes additional compensation.

Name: **Mr. Yousef Mahimoud Shaeira**
Signature: _____
Date: **6/2/2019**

See Attachment

Consultant Comments:

Status:

- A: Approved
- B: Temporary Approved
- C: Revise and Resubmit
- D: Rejected
- I: For Information

Discipline

- Geotechnical
- Architectural
- Civil / Structural
- Mechanical
- Electrical
- HSE

Louis Berger Engineer

Name: **Hamed Alkhatib**
Signature: _____
Date: **24 Feb 2019**

Louis Berger Project Director

Name: **DAVE HUGHES**
Signature: _____
Date: **25/02/19**

SPECIAL KINGDOM PROJECTS DEPARTMENT
National Guard Project Division
Thuwal, Jeddah
Tel. (012) 422-4175, Fax. (012) 422-4392

DOCUMENT TRANSMITTAL

Transmittal No.: NGHPD/PH-II/AZM-T-181/17

Date: 5-Feb-17

TO: AZMEEL Contracting Co.
Attn: Marwan Zahnan, Proj. Manager

Copy:

- | | | |
|---|--|---|
| <input type="checkbox"/> Administration | <input checked="" type="checkbox"/> Project Engineer | <input checked="" type="checkbox"/> Control (RGC) |
| <input checked="" type="checkbox"/> QA / Material | <input type="checkbox"/> Safety | <input type="checkbox"/> File |

Transmitted herewith are the following:

DOCUMENT TYPE		
<input type="checkbox"/> CALCULATION(S)	<input type="checkbox"/> DRAWING(S)	<input type="checkbox"/> FORM(S)
<input type="checkbox"/> LETTER(S)	<input type="checkbox"/> REPORT(S)	<input checked="" type="checkbox"/> OTHER DOCUMENT(S)

TYPE OF ACTION				
<input checked="" type="checkbox"/> ACTION	<input type="checkbox"/> INFO	<input type="checkbox"/> REVIEW	<input checked="" type="checkbox"/> UPDATE	<input type="checkbox"/> OTHERS

ITEM NO.	QUANTITY	DESCRIPTION
1	1	RTA-NGFCP-C1-M-MS-2013-01 - Heavy Duty Manhole Cover for Water Tank & Sump Box.

REMARKS:

Please see attached RTA-NGFCP-C1-M-MS-2013-01 for Information and appropriate action.
Remarks- **No Objection As Noted (See attached SAPMT comments sheet)**



Transmitted by:

YAS
Saleh O. Al-Ghamdi
Saleh O. Al-Ghamdi, Project Manager
SKPD/National Guard Project Division

Received by:

Name: _____	Date: _____
Signature: _____	

REQUEST FOR TECHNICAL APPROVAL

TO: Mr. Saleh O. Al-Ghamdi
Company Representative (SAUDI ARAMCO)
Special Kingdom Project Dept.
National Guard Project Division
Rm. 05, SAPMT Site Office Bldg.
Thuwal, Jeddah, Saudi Arabia
ATTN.: Mr. Mohammed G. Al-shehri
Sr. Project Engineer
CC: Mr. Jose Manasan
Project Material Specialist
Azmeel Contracting Co.
P.O. Box 3043
Dammam 31471
Saudi Arabia
Tel: 013 826-7250
Fax: 013 826-2195

FROM:

BIJO No.: 25-00034

CONTRACT No.: 6600033421

PROJECT TITLE: NATIONAL GUARD FAMILY COMPOUND PROJECT

LOCATION: THUWAL, SAUDI ARABIA

No. of Copies: 3

SUBMITTAL CODE:
A Architectural
C Civil
S Structural
M Mechanical
E Electrical
I Instrumentation
O Others

SPECS REF.:

DIV. No.:

SECTION No.:

DRAWING REFERENCES:

APPLICABLE SAUSSINSIP:

REFERENCE SUBMITTAL NO.: RTA-NGFCP-C1-M-MS-2013-01

DATE: 22-Jan-17

REVISION NO.: 1

DUMMY P.O. NO.: N/A

LEVEL OF INSPECTION: NI

QTY. & ISSUE UNIT	BRIEF DESCRIPTION	9COM	MFR. NAME / PLANT I.D. NO. / ADDRESS	LOCAL VENDOR REP. ADDRESS & I.D. NO.	(FOR SAUDI ARAMCO USE ONLY) REVIEW/COMMENTS/APPROVAL/ACTION
6000001135	Heavy Duty Manhole Cover for Water Tank and Sump Box Items Code: M60S-182-1 & CFSG-743-1			NATIONAL CAST IRON PRODUCTS FACTORY	
<div style="border: 2px solid blue; padding: 10px; width: fit-content; margin: 0 auto;"> <p>RECEIVED</p> <p>23 JAN 2017</p> <p>NATIONAL GUARD HOUSING PROJECT DIVISION</p> <p>Signature: <i>[Signature]</i> Teln: 9-57</p> </div>					
NOTE: One Time Approval					

Prepared by: *[Signature]*
Infrastructure manager
22/01/2017
Date

Reviewed by: *[Signature]*
Syed Ishaq Hussain
FOCS
22/01/2017
Date

Reviewed by: *[Signature]*
Mohammed Irfan Ahmed
Procurement Manager
22/01/2017-24/1/2017
Date

Reviewed by: *[Signature]*
Mr. Jose Manasan
PMT Material Specialist
11/25/2017
Date

Approved by: *[Signature]*
Mr. Mohammed G. Al-shehri
Sr. Project Engineer / SAPMT
21/1/17
Date

Approved by: *[Signature]*
SAIR, SA VID/CIMU
Date

REQUEST FOR TECHNICAL APPROVAL

SAPMT COMMENT SHEET

PROJECT TITLE: NATIONAL GUARD FAMILY COMPOUND RESIDENTIAL AND INFRASTRUCTURE PROJECT

CONTRACT NUMBER: 6600033421

SUBMITTAL REFERENCE NUMBER: HEAVY DUTY MANHOLE COVER FOR WATER TANK & SUMP BOX# RTA-NGFCP-C1-M-MS-02013-01 - Jan 23 '17

ITEM	DESCRIPTION / DWG # / DOC #	COMMENTS	INITIATOR'S COMMENTS
1	Heavy duty Manhole Cover for Water Tank & Sump Box	Contractor to ensure that all comment as per compliance sheet shall be applied and followed.	Julius Garcia
2	Heavy duty Manhole Cover for Water Tank & Sump Box	BS Standard as per attached manufacturer submittal shall meet the requirements provided in the specification.	Joey S. Salalila
3	Heavy duty Manhole Cover for Water Tank & Sump Box	Contractor to provide shop drawings and sample that will be applied in this project and to be approved as indicated in the specification	Joey S. Salalila
4	Heavy duty Manhole Cover for Water Tank & Sump Box	Contractor to ensure that all highlighted Catalogue as per the submittal shall be supplied and complied with Project Specifications and requirements.	Joey S. Salalila
5	Heavy duty Manhole Cover for Water Tank & Sump Box	All requirements or deviations in the drawings shall be contractor risk and check by their Technical Team. There shall be no impact in cost or Project Schedule.	Joey S. Salalila
6	Heavy duty Manhole Cover for Water Tank & Sump Box	This submittal is "NO OBJECTION AS NOTED"	Joey S. Salalila 

Note:

- 1) This is a supplemental sheet to the RTA form.
- 2) Comments herein does not relieve the contractor of his responsibilities under the terms of the contract nor authorize him for additional compensation

COMMENTS CONCURRED BY:	PAGES
MOHAMMED G. AL-SHEHRI DATE	1 OF 1
SA, SENIOR PROJ. ENGR.	



Material PO Long Text Description.

ZHR00301 222 (ERC)
Doc by : PMH5A03

Saudi Aramco Systems
Material PO Long Text Description.

01/03/16 16:32:50 Page: 1
Trans : ZH0000

Material Number: E000001105

PO Text

PO Text

END

***** End of Report ZHR00301 *****

ats window contents



REQUEST FOR SAMPLE APPROVAL

طلب الموافقة على عينة

المملكة العربية السعودية
الحرس الوطني بالقطاع الغربي
إدارة المشاريع



Project : المشروع : تجديد شبكة الصرف الصحي بالمدينة السكنية بالحرس الوطني القطاع الغربي		Project No : القسم المختص : معماري إنشائي ميكانيكا كهرباء A S M E <input type="checkbox"/> <input checked="" type="checkbox"/> <input type="checkbox"/> <input type="checkbox"/>	
Consultant : الاستشاري : إدارة المشاريع بالقطاع الغربي الحرس الوطني		Submittal No: رقم التقديم : ... ٢	
Contractor : المقاول : شركة المحمل لخدمات المرافق		Submittal date : تاريخ التقديم : ٢٠١٨-١٠-٣	
Add. : عنوان الوكيل :	Agent : الوكيل : المصنع الوطني لمنتجات الزهر المحدودة	Document type : نوع التقديم :	
P.O. Box :	S. Name: اسم العينة : إخطية المناهل	Location : مكان الاستخدام : المدينة السكنية بجده	
Tel :	Quantity : التمية المرفقة : ٢٤٤	Origin : بلد المنشأ : السعودية	
Fax :	Proposed Spec. for item : مواصفات المقترحة للبند : حسب الصور المرفقه	Spec. as per contract : مواصفات البند حسب العقد : خطام من الحديد الزهرج	
Notes & Comment : الملاحظات :			
Eng. Signature and note : ملاحظات و توقيع المهندس المختص : Approved موافقة و يعتمد <input checked="" type="checkbox"/> Approved with noted موافقة مع الملاحظات <input type="checkbox"/> Disapproved مرفوض و يعاد للمقاول <input type="checkbox"/> Eng./ مهندس / عبدالرحمن عبدالاله ابو الخير		Signature of contractor : توقيع مهندس المقاول : Eng./ مصطفى عبد المطلب محمد	

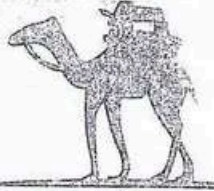

شركة المحمل لخدمات التمرافق
AL MAHMAL FACILITIES SERVICES COMPANY

التاريخ: 1440/02/07 هـ
الموافق: 2018/10/16

المحترمين.
المحترم.

السادة/ وزارة الحرس الوطني
عناية المهندس /عبد الرحمن ابو الخير

السلام عليكم ورحمة الله وبركاته،،،

الموضوع: اعتماد أغطية المناهل المستخدمة بمشروع تجديد مناهل الصرف الصحي بالمدينة السكنية
التابعة للحرس الوطني بجدة

نرجو من سعادتكم التكرم والإطلاع على الشركة المدرج إسمها والمتخصصه في تصنيع وتوريد أغطية الحديد الزهر المستخدمة في مناهل الصرف الصحي و المراد إستخدامها في المشروع اعلاه كمورد رئيسي للأغطية.

١- شركة المصنع الوطني لمنتجات الزهر المحدودة

للمناهل الرئيسية :-

- غطاء من الحديد الزهر مع القاعدة بدون قفل
- قدرة تحمل 40 طن
- قطر 600 م للغطاء و 750 للقاعدة
- عمق 10 سم
- مطلي بتومين أسود
- المواصفة العالمية BSS497/A

لغرف التفتيش الداخلية :-

- غطاء من الحديد الزهر مع القاعدة بدون قفل
- قدرة تحمل 20 طن
- قطر 600 م للغطاء و 750 للقاعدة
- عمق 10 سم
- مطلي بتومين أسود
- المواصفة العالمية BSS497/A

لذا نرجو من سعادتكم توجيهنا حيال موافقتكم على المورد المذكور اعلاه ..

ولكم جزيل الشكر ،،،



TRANSMISSION
ENGINEERING & PROJECTS SECTOR
DEVELOPING TRANSMISSION AREA DEPARTMENT
NORTH WEST PROJECTS DIVISION
TABUK ROAD COMPLEX - MADINAH

TEL. : +966-4-8619120
FAX : +966-4-8619121
E-MAIL : DTANWDV@se.com.sa



الشركة السعودية للكهرباء
Saudi Electricity Company

REF. : 03030- 2045-10

CONTRACT NO. : 20931058/00

DATE : 23-06-2010 (01-07-1431 H)

CONTRACT NAME : Construction and Installation
of 110kv Power Cables & OHTL for Bani Al-Najjar
S/S at Madinah

CORRESPONDING TO : sec3/D-03388 01 21-6-2010

ATTACHMENT : (-)

TO: Engr. Mohammed Ali Al-Keylani
General Manager
M/S DEEM , Jeddah
Fax: 02-6946510

Subject: Cast Iron Cover & Frame for Manhole/Handhole (DTS- D-183)

We have reviewed the following drawings / documents and our comments as under:

Item #	Document/Drawing #	Rev.	Document Tittle	Status
01	WE-076999	0	Cast Iron Cover & Frame for Manhole/Handhole Manufacturer : National Cast Iron Factory	"A"

Status of drawings/documents is indicated in the last column with the attached sheet of comments if any.

LEGEND :-

A	Approved
B	Approved Except As noted
C	Approved Except As noted & Re-Submit
D	Rejected
F	For information only

This is for your information and necessary action.

Should you have any question, please contact **Engr. Mohammed F. Al-Raddadi** on 8619131.

Regards ,,,,,

ENGR. MOHAMMED F. AL-RADDADI

المتابعة المسؤولة والشاملة

لتففيذ عقود مشاريعنا

هي غايتنا

**PROJECT MANAGER NW PROJECTS
AL MADINAH AL MUNAWARAH**

SMA



mtmm

Mohamed Turk Mott MacDonald
Engineering Consultancy

NATIONAL GRID SAUDI ARABIA	
ENGINEERING AND DESIGN DEPARTMENT	
ENGINEERING & DESIGN HIGH VOLTAGE SYSTEMS	
TALIB AL-ILM STREET	AL-RUWAIS JEDDAH, SAUDI ARABIA.
TEL: 6147011/6147047 EXT # 30	FAX: 6146654
e-mail: AURahman@se.com.sa	

12 JAN 2015

DOCUMENT TRANSMITTAL SHEET

DATED(G): 11-01-2015
DATED(H): 20-03-1436

NG REFERENCE National Grid SA/AL-FANAR/MIU-2 Madinah/DTS-175Rev.00
 CONTRACTOR REFERENCE AL-FANAR/National Grid SA/MIU-2 Madinah/DTS-0175 Rev.00
 DATE 16/12/2014 (G)
 TO : Division Manager -PRWMNDV.
 ATTENTION : ENG. NABEEL G. KHUSHAIM
 PROJECT TITLE : Construction of New 110 kV/13.8 kV Substation at Madinah Islamic University-2 in Madinah.
 CONTRACT # :11WN1078

STATUS OF THE SUBMITTED DRAWINGS /DOCUMENTS IS INDICATED BELOW:

SI#	DOC/DWG#	REV	DESCRIPTION	STATUS*
1	WE-243689	00	Technical Submittal for Handhole Covers Suppliers : National Castiron Products	A

IT SHALL BE READ IN ALONG WITH THE COMMENTS ON THIS LETTER ATTACHMENT.
 IF YOU HAVE ANY QUERY, PLEASE CONTACT: ENG. MOHAMED ANWAR ON TEL# 6147011/6147047 EXT. # 51

* General notes:

- Civil drawings shall be coordinated with its relative approved Electrical/Mechanical drawings before site execution.
- Future changes and modifications shall be clearly Highlighted/Indicated by revision clouds.

LEGEND:	
A	DULY APPROVED
B	APPROVED WITH COMMENTS
C	APPROVED EXCEPT AS NOTED- RESUBMITT
D	REJECTED
E	INFORMATION

CD UPLOADED
YES
STAMPED
YES

CD UPLOADED	1
STAMPED	2
FAX	

ANWAR
18802

18609

Engr. Asad Ur Rahman
PROJECT MANAGER
DESIGN & ENGINEERING
MTMM

ΦMS
FYA

	NUMBER: Y02-03-00-06/01	AL FANAR CO P.O.Box 301, Al Nafi, Northern Ring Road Between Exit 5 & 6 Tel. No's. : 920006111 Ext 4708 , Fax No.: 011-278511 E-mail: mohd.omar@alfanar.com	
	DATE OF ISSUE: 01/06/1435		
Contract Title : DESIGN & CONSTRUCTION OF 8H SUBSTATION Contract No. : PIC P-7705			
SUBMITTAL FOR		Date: 21.05.2018	
<input type="checkbox"/> Shop Drawings <input type="checkbox"/> Material <input checked="" type="checkbox"/> Others <input checked="" type="checkbox"/> Approval <input type="checkbox"/> Verification <input type="checkbox"/> Information <input type="checkbox"/> Record <input type="checkbox"/> Deviation <input type="checkbox"/> Others		Submittal No. : PE182/ALFF/RC/7705/PQF/089	
ATTENTION: ENGR. SYED MOHAMMAD TANWEER AUTHORIZED REPRESENTATIVE CONSTRUCTION DEPT		EWR NO. / CSG :	
<input checked="" type="checkbox"/> First Submittal	<input type="checkbox"/> Re-Submittal (Previous Sub. No.) :	Previous EWR No.:	
Subject Reference Spec. :		02813	
Item Description / Subject: PREQUALIFICATION DOCUMENTS OF M/S. NATIONAL CAST IRON PRODUCTS FACTORY CO LTD. FOR HANDHOLE COVERS FOR FOC DUCT BANK			
List of Attachments: 1 ORIGINAL + 1 COPY			
		"Having checked this submittal, we certify that it conforms to the requirements of the Contract Documents in all respects, except otherwise indicated herein." Checked by Lead Project Engineer : <u>Engr. Abdul Kareem</u> Signed by: Project Manager <u>Engr. Muhammad Omar</u> Date: 21.05.2018 Date: 21.05.2018	
Royal Commission Review / Construction Support Group			
<input type="checkbox"/> AR	<input type="checkbox"/> EE	<input type="checkbox"/> ME	<input type="checkbox"/> SE
<input type="checkbox"/> Other			
Projects Controls	<input type="checkbox"/> Cost	<input type="checkbox"/> Quantity Survey	<input type="checkbox"/> Estimate <input type="checkbox"/> Schedule
Royal Commission / MSC Review and Approval Status			
<input checked="" type="checkbox"/> (A) Work May proceed <input type="checkbox"/> (B) Work May proceed - Minor Comment <input type="checkbox"/> (C) Work May proceed Except as Noted <input type="checkbox"/> (D) Disapproved <input type="checkbox"/> Acceptable with no comments <input type="checkbox"/> Acceptable with minor comments <input type="checkbox"/> Unacceptable / Rejected <input type="checkbox"/> Other Comments: See below		<input checked="" type="checkbox"/> Re-submittal not required. Incorporate comments and proceed. <input type="checkbox"/> Re-submittal required. Incorporate comments. Don't proceed. <input type="checkbox"/> Submittal incomplete. Complete & re-submit again. <input type="checkbox"/> Submittal inconsistent with contract.	
NOTE: Shop Drawing review require "Released for Construction" sticker before proceeding.		ATTACHMENTS: <input type="checkbox"/> Engineering Review Comments Sheet(s). <input type="checkbox"/> EWR List of Submitted Materials indicating the Review status submitted materials. <input type="checkbox"/> Contractor Drawing submittal sheet(s) indicating status of submitted drawing(s). <input type="checkbox"/> Other enclosures / attachments.	
CSG Log #: 73869	Reviewer: <u>Tanweer</u>	Date:	SUPERVISOR, CSG: _____ Date: _____
Receipt Date:			
RC / MSC CONSTRUCTION			
The review and approval is provided conditionally that the submittal is in compliance with the contract documents. This approval shall not be construed as an approval of a change in Contract scope or price. A prompt response shall be made by the Contractor in writing if any comment is considered not to be within the terms of the Contract.			
ADDITIONAL COMMENTS: <u>Acceptable</u>			
Project File No.:	<u>28</u>		
EWR No.: CSG:	<u>73869</u>	For RC/MS	<u>[Signature]</u>
Ref. Number	PE182/ALFF/RC/7705/PQF/089	Date	<u>24 May 2018</u>
CC: Chrono			

Document Submittal Form

Contractor : Civil Works Company limited. (CWC)
 Contract No. : 019/005/0014/8/00/00/3
 Project No.: S3-18002
 Project Name : Maintenance and Improvement Network Storm Water and Networks Reduce the Level of Groundwater in South and East Jeddah
 Ref. No. : DT-40 REV-2
 Location :
 Date : 01-12-2018

Please check appropriate box:

- | | | |
|--|---|--|
| <input type="checkbox"/> As Built | <input type="checkbox"/> Inspection Request | <input type="checkbox"/> Product Data |
| <input type="checkbox"/> Bill of Quantities | <input type="checkbox"/> Job Order | <input type="checkbox"/> Report |
| <input type="checkbox"/> Bank Warranty | <input type="checkbox"/> Letter | <input type="checkbox"/> Request for Information |
| <input type="checkbox"/> Certificate | <input type="checkbox"/> Material Sample | <input type="checkbox"/> Schedule |
| <input type="checkbox"/> Drawing | <input type="checkbox"/> Manual | <input type="checkbox"/> Shop Drawing |
| <input type="checkbox"/> Engineering Calculation | <input checked="" type="checkbox"/> Pre-qualification | <input type="checkbox"/> Test Reports |
| <input type="checkbox"/> GIS or CAD | <input type="checkbox"/> Procedure or Methodology | <input type="checkbox"/> Others |

Purpose:

- For Information For Review & Approval As Requested

Subject: **Pre-qualification certificate of-NATIONAL CAST IRON PRODUCTS-FACTORY CO.LTD.(NCPF) For S3-18002 Project.**

Document Description:

SR. No.	Document No.	Document Name	Rev.	Hard Copy	Soft Copy
1	DT-40 REV-2			1	

Mouchel Review & Approval Status

- Approved (Work may proceed)
 Approved as Noted (Work may proceed subject to Incorporation of Comments)
 Revise and Resubmit (Work may not proceed)

Mouchel Review & Approval Status

Name:

Sign:

Date:

Comments: 1) Conditionally approval subject to SASCO certificate and MOT.
 2) Sample shape and size as per Project Specs and third party lab within their IR.

Contractor Project Manager

Name: Eng Syed Abdel Aziz Keshawi

Sign:

Date:



Mouchel Department Manager

Name: Mr PP TUKIM

Sign:

Date:

Document Submittal Form

Contractor : Civil Works Company limited. (CWC)
 Contract No. : 019/005/0014/8/00/00/3
 Project No.: S3-18002
 Project Name : Maintenance and Improvement Network Storm Water and Networks Reduce the Level of Groundwater in South and East Jeddah
 Ref. No. : DT-40 REV-1
 Location :
 Date : 08-10-2018

Please check appropriate box:

- | | | |
|--|---|--|
| <input type="checkbox"/> As Built | <input type="checkbox"/> Inspection Request | <input type="checkbox"/> Product Data |
| <input type="checkbox"/> Bill of Quantities | <input type="checkbox"/> Job Order | <input type="checkbox"/> Report |
| <input type="checkbox"/> Bank Warranty | <input type="checkbox"/> Letter | <input type="checkbox"/> Request for Information |
| <input type="checkbox"/> Certificate | <input type="checkbox"/> Material Sample | <input type="checkbox"/> Schedule |
| <input type="checkbox"/> Drawing | <input type="checkbox"/> Manual | <input type="checkbox"/> Shop Drawing |
| <input type="checkbox"/> Engineering Calculation | <input checked="" type="checkbox"/> Pre-qualification | <input type="checkbox"/> Test Reports |
| <input type="checkbox"/> GIS or CAD | <input type="checkbox"/> Procedure or Methodology | <input type="checkbox"/> Others |

Purpose:

- For Information For Review & Approval As Requested

Subject: **Pre-qualification certificate of-NATIONAL CAST IRON PRODUCTS FACTORY CO.LTD.(NCPF) For S3-18002 Project.**

Document Description:

SR. No.	Document No.	Document Name	Rev.	Hard Copy	Soft Copy
1	DT-40 REV-1			1	

Mouchel Review & Approval Status

- Approved (Work may proceed)
 Approved as Noted (Work may proceed subject to Incorporation of Comments)
 Revise and Resubmit (Work may not proceed)

Mouchel Review & Approval Status

Name:

Sign:

Date:

Comments: 1) Attached MOT approval expired dated 11/5/1436 (H).
 2) SASO certificate has not provided. manufacturer
 3) Attached ISO 9001-2015 not define meet requirement International Code of Std.

Contractor Project Manager

Name: Eng Syed Abdel Aziz Keshawi

Sign:

Date:

Received by

Name:

Sign:

Date: 08 OCT 2018

Mouchel Department Manager

Name:

Sign:

Date:

Jeddah Municipality Projects

mouchel
building great relationships

Document Submittal Form

Contractor : Civil Works Company limited. (CWC)
 Contract No. : 019/005/0014/8/00/00/3
 Project Name : Maintenance and Improvement Network Storm Water and Networks Reduce the Level of Groundwater in South and East Jeddah
 Location :
 Project No.: S3-18002
 Ref. No. : DT-40
 Date : 24-05-2018

Please check appropriate box:

- | | | |
|--|---|--|
| <input type="checkbox"/> As Built | <input type="checkbox"/> Inspection Request | <input type="checkbox"/> Product Data |
| <input type="checkbox"/> Bill of Quantities | <input type="checkbox"/> Job Order | <input type="checkbox"/> Report |
| <input type="checkbox"/> Bank Warranty | <input type="checkbox"/> Letter | <input type="checkbox"/> Request for Information |
| <input type="checkbox"/> Certificate | <input type="checkbox"/> Material Sample | <input type="checkbox"/> Schedule |
| <input type="checkbox"/> Drawing | <input type="checkbox"/> Manual | <input type="checkbox"/> Shop Drawing |
| <input type="checkbox"/> Engineering Calculation | <input checked="" type="checkbox"/> Pre-qualification | <input type="checkbox"/> Test Reports |
| <input type="checkbox"/> GIS or CAD | <input type="checkbox"/> Procedure or Methodology | <input type="checkbox"/> Others |

Purpose:

- For Information For Review & Approval As Requested

Subject: Pre-qualification certificate of-NATIONAL CAST IRON PRODUCTS FACTORY CO.LTD.(NCPF) For S3-18002 Project.

Document Description:

SR. No.	Document No.	Document Name	Rev.	Hard Copy	Soft Copy
1	DT-40			2	
					1

Mouchel Review & Approval Status

- Approved (Work may proceed)
 Approved as Noted (Work may proceed subject to Incorporation of Comments)
 Revise and Resubmit (Work may not proceed)

Mouchel Review & Approval Status

Name:
 Sign: 
 Date:

Comments: Contractor to not define BOQ item material intend for Prequalification Company. Submit contract BOQ Reference, and also Comply review comment sheet (see attached).

Contractor Project Manager

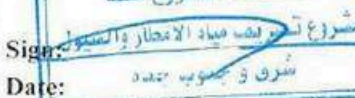
Name: Eng. Ali El Sherbiny
 Sign: 
 Date:

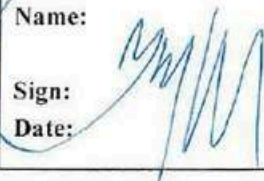

Mouchel Department Manager

Name:
 Sign: 
 Date:

SUPPLIERS PRE-QUALIFICATION SUBMITTAL REVIEW FORM

Discipline	Contractor :	Civil Works Company Limited (CWC)		
BT-Bridges & Tunnel	Contract No:	019/005/2/001/0014/10/00/3	Project No.	S3-18002
H-Hydraulics	X	Project:	Maintenance and Improvement of Storm Water and Networks Reduce the level of Groundwater in south and East Jeddah Sou	
RH-Road & Highways	Submittal No:	DT-49	Status:	Revise & Resubmit
BF- Building & Facilities	Please see below MME comments. If in red color, contractor must rectify all necessary items in the revised/next submission for final review.			
ME-Mechanical & Electrical	These documents have been reviewed for general conformance with the contract. Such review does not relieve the contractor of his responsibilities under the authorized terms and condition of the contract.			
LG-Landscape & Gardens				

No.	Item Description	MME Comments	Contractor Response
1	Company Profile	Provided, acceptable	
2	List of Materials to be Supplied	Not Provided as per contract material BOQ item description DI either Cast iron	
3	Organizational Chart	Provided, acceptable	
4	Commercial Documents/Government Registrations		
4.1	Company Registration	Provided and validity period until 08/11/1439(H)	
4.2	Industrial License	Provided and validity period until 08/08/1440(H)	
4.3	Zakat Certificate	Provided and validity period until 25/08/1440(H)	
4.4	Chamber of Commerce Certificate	Provided and validity period until 08/11/1439(H)	
4.5	GOSI	Provided and validity period until 01/10/1439(H)	
5	ISO or other Quality Certifications: 9001-2008, 14001	Not Provided	Provided and validity until
6	SASO Certification	Not Provided	
7	List of Machineries/Equipment (supporting with valid Third-Party Calibration Certificates)	Not Provided	
8	Vendor Previous Approvals	Provided, acceptable	
9	Completed Project References	Provided, acceptable	
10	Others (As deemed necessary)	This is only the Pre-qualification of contractor's proposed supplier NCPF Products Contractor's should submit product/material submittal separately (along with relevant test results shall have original stamp NCPF, if applicable) for FINAL APPROVAL	

- Remarks:**
- Contractor shall submit material sample of relevant products (along with all relevant documents and test results must have NCPF . original stamp) for Final review & approval.
 - Material/Product from the supplier or manufacturer shall be used only after approval of the relevant material/product from the Engineer.

Checked/Reviewed By: Muhammed Salem Mohammed Majid Tariq Hakim
 Title: Hydraulics Engineer QA/QC Engineer O&M Manager
 Signature: _____
 Date: _____

27/5/18

عقد نقل المخلفات التجارية والإنشائية

التاريخ: ١٤٤٣ / ٢ / ١٩ هـ

بمعون الله تعالى تم إبرام هذا العقد في ١٩ / ٢ / ١٤٤٣ هـ، الموافق: ١٩ / ٢ / ٢٠٢١ م، بين كل من:

(١) شركة عذيب للصيانة والخدمات: س.ت: ٤٠٣٠١٩٤٤٤٠ صادر من جدة بتاريخ ١٩/٨/١٤٤١ هـ.

وعنوانه: حي (سباد) شارع رقم () هاتف: ١٢٦٩١٩٢٢ فاكس: ١٢٦٤٧١٤٢٨

ويمثله للتوقيع في هذا العقد: **حسن ذوي العيص** بصفته **سؤول تطوير الأعمال (طرف أول)** الطرف الثاني

(٢) شركة المصنع الوطني طنجة بالزهر (مالك المحل التجاري) سجل تجاري رقم () تاريخ (١٤٣٨/١١/١٩)

تمهيداً: حيث أن الطرف الأول مصروح له بالعمل في نقل النفايات التجارية ويرغب الطرف الثاني بالتعاقد معه لنقل المخلفات الناتجة من

محلاته التجارية إلى مرادم النفايات التابع للأمانة أو أي مكان تحدده الأمانة ضمن حدود إشرافها فقد تم الاتفاق على ما يلي:

أولاً: اتفق الطرفان على أسعار خدمة نقل النفايات الخاصة بالطرف الثاني حسب الآتي:

أن تكون قيمة العقد السنوي مبلغاً وقدره () ويتم تقسيطه على ١٢ شهراً.

حجم الحاوية	رقمها	الأجر الشهري	حجم الحاوية	رقمها	الأجر الشهري
٢ ياردة			٢٢ ياردة		
٦ ياردة			٢٤ ياردة		
٢٠ ياردة		١٥٠٠ ريال	٢٧ ياردة		
عدد الرفعات					
إحداثيات الموقع					

ترفع الحاويات يومياً وتكون بغطاء داخل الموقع المحدد والالتزام بتنظيف ما حولها من نفايات ومبعضرات.

ملاحظة: ① هذا العقد (الحاوية) مفردة.

الطرف الأول: **حسن ذوي العيص** الطرف الثاني: **شركة المصنع الوطني طنجة بالزهر**

التوقيع: **حسن ذوي العيص** التوقيع: **حسن ذوي العيص**

الختم: الختم

التاريخ: ١٩ / ٢ / ١٤٤٣ هـ الختم

اعتماد مدير تطوير الأعمال
للصيانة والخدمات
التوقيع: **حسن ذوي العيص**
المحقة الغربية س.ت: ٤٠٣٠١٩٤٤٠
تم توقيع هذا العقد تحت إشراف أمانة مدينة جدة

مصادقة الأمانة: الإدارة العامة لمشاريع النظافة

شروط خاصة

- أولاً : مدة العقد هي (١٢) شهراً من تاريخ توقيع العقد.
- ثانياً : يقوم الطرف الأول بنقل المخلفات من محلات الطرف الثاني حسب الجدول الزمني المتفق عليه (عدد السحبات الشهرية).
- ثالثاً : يقوم الطرف الثاني بدفع المستحقات شهرياً حسب الفاتورة المقدمة من الطرف الأول خلال أسبوع من نهاية شهر الخدمة على أن يتم سداد دفعة مقدمة كتأمين مبلغ وقدره (٣٠٠٠٠٠) ريالاً (عبارة عن (٢) شهر من قيمة العقد تصفي نهاية العقد.
- رابعاً : اتفق الطرفان على أسعار نقل النفايات الخاصة بالطرف الثاني حاوية سعة (٢٠) ياردة عدد السحبات شهرياً (٣) بقيمة (١٥٠٠٠) ريال فقط شهرياً.
- خامساً : يجدد العقد تلقائياً لمدة مماثلة إلا في حال عدم رغبة أي طرف بالتجديد فيجوز للطرف الثاني والإمانة خطياً بعدم رغبته في التجديد وذلك بمدة شهر قبل تاريخ انتهاء هذا العقد.
- سادساً : يتعهد الطرف الأول بعدم الاستفادة من المخلفات التجارية إلا بموافقة خطية من الأمانة.
- سابعاً : يتعهد الطرف الثاني بعدم عرقلة عمل الطرف الأول وتمكينه من الوصول إلى الحاويات وإزالة معوقات عمل الطرف الأول إذا وجدت.
- ثامناً : يتعهد الطرف الأول بالاستجابة للطلبات الطارئة لخدمة تفريغ الحاويات على مدار الساعة وخلال الإجازات الرسمية والأعياد (٧ أيام في الأسبوع).
- تاسعاً : يتعهد الطرف الأول بصيانة ودهان وغسيل وتطهير الحاويات حسب لوائح الأمانة.
- عاشراً : يتعهد الطرف الأول بإحلال حاوية بديلة قبل سحب أي حاوية توجب الظروف سحبها.
- حادي عشر : يتعهد الطرفان بالحفاظ على موقع الحاوية المتفق عليه والذي توافق عليه الأمانة.
- ثاني عشر : يتحمل الطرف الثاني أي أضرار تلحق بالحاويات من حيث الصدم والحوادث.
- ثالث عشر : على الطرفين الحرص التام على مطابقة مواصفات الحاويات لأنظمة الأمانة في السعات والأحجام واللون والصنع والأبعاد وأن تكون ملائمة للغرض منها (الاستخدام).
- رابع عشر : في حالة تقديم الطرف الأول خدمة رفع النفايات والتخلص منها فإن المقصود بهذه النفايات هي المواد الصلبة فقط الناتجة من منشأة العميل ويستثنى من خدمة جمع النفايات المواد المشعة والمواد سريعة الاشتعال والتبخر والمواد القابلة للانفجار والكفريات والمواد السامة والمخلفات الطبية وأي مواد أخرى خطيرة. وفي حالة قيام العميل بوضع أي من المواد الخطرة المذكورة أعلاه ضمن المواد الصلبة فإن العميل يتحمل الأضرار والغرامات والمستوثليات الناتجة عن ذلك.
- خامس عشر : يلتزم الطرف الثاني باستعمال حاويات الطرف الأول للمخلفات المتفق عليها فقط وحسب ما تضمنته الخطة التنفيذية المقدمة من خلال الطرف الأول.
- سادس عشر : أي خلاف ينشأ بين طرفي هذا العقد يقوم الطرفان كلاً على حده بإعلام الأمانة خطياً ويتعهد الطرفان بعدم الإخلال بخطة التنفيذ ويتعهد الطرف الثاني بدفع المستحقات الشهرية للطرف الأول حتى صدور الحكم من جهة الاختصاص.
- سابع عشر : أقر الطرفان بالاطلاع على كافة بنود العقد وعليه جرى التوقيع



١٥٠٠٠

TRANSMISSION
ENGINEERING & PROJECTS SECTOR
DEVELOPING TRANSMISSION AREA DEPARTMENT
NORTH WEST PROJECTS DIVISION
TABUK ROAD COMPLEX - MADINAH

TEL. : +966-4-8619120
FAX : +966-4-8619121
E-MAIL : DTANWDV@se.com.sa



الشركة السعودية للكهرباء
Saudi Electricity Company

REF. : 03030- 2045-10 CONTRACT NO. : 20931058/00
DATE : 2010-06-01 (01-07-1431 H) CONTRACT NAME : Construction and Installation
of 110kv Power Cables & OHTL for Bani Al-Najjar
S/S at Madinah
CORRESPONDING TO : سعج/د-03388 21-6-2010
ATTACHMENT : (-)

TO: Engr. Mohammed Ali Al-Keylani
General Manager
M/S DEEM, Jeddah
Fax: 02-6946510

Subject: Cast Iron Cover & Frame for Manhole/Handhole (DTS- D-183)

We have reviewed the following drawings / documents and our comments as under:

Item #	Document/Drawing #	Rev.	Document Tittle	Status
01	WE-076999	0	Cast Iron Cover & Frame for Manhole/Handhole Manufacturer : National Cast Iron Factory	"A"

Status of drawings/documents is indicated in the last column with the attached sheet of comments if any.

LEGEND :-

A	Approved
B	Approved Except As noted
C	Approved Except As noted & Re-Submit
D	Rejected
F	For information only

This is for your information and necessary action.

Should you have any question, please contact Engr. Mohammed F. Al-Raddadi on
8619131.

Regards ,,,,

ENGR. MOHAMMED F. AL-RADDADI

المتابعة المسئولة والشاملة
لتنفيذ عقود مشاريعنا
هي غابتنا

PROJECT MANAGER NW PROJECTS
AL MADINAH AL MUNAWARAH

SMA



mtmm

Mohamed Turki Mott MacDonald
Engineering Consultancy

NATIONAL GRID SAUDI ARABIA	
ENGINEERING AND DESIGN DEPARTMENT	
ENGINEERING & DESIGN HIGH VOLTAGE SYSTEMS	
TALIB AL-ILM STREET	AL-RUWAIS JEDDAH, SAUDI ARABIA.
TEL: 6147011/6147047 EXT # 30	FAX: 6146654
e-mail: AURahman@se.com.sa	

12 JAN 2015

DOCUMENT TRANSMITTAL SHEET

DATED(G): 11-01-2015
DATED(H): 20-03-1436

NG REFERENCE National Grid SA/AL-FANAR/MIU-2 Madinah/DTS-175Rev.00
 CONTRACTOR REFERENCE AL-FANAR/National Grid SA/MIU-2 Madinah/DTS-0175 Rev.00
 DATE 16/12/2014 (G)
 TO : Division Manager -PRWMNDV.
 ATTENTION : ENG. NABEEL G. KHUSHAIM
 PROJECT TITLE : Construction of New 110 kV/13.8 kV Substation at Madinah Islamic University-2 in Madinah.
 CONTRACT # :11WN1078

STATUS OF THE SUBMITTED DRAWINGS /DOCUMENTS IS INDICATED BELOW:

SI#	DOC/DWG#	REV	DESCRIPTION	STATUS*
1	WE-243689	00	Technical Submittal for Handhole Covers Suppliers : National Castiron Products	A

IT SHALL BE READ IN ALONG WITH THE COMMENTS ON THIS LETTER ATTACHMENT.
 IF YOU HAVE ANY QUERY, PLEASE CONTACT: ENG. MOHAMED ANWAR ON TEL# 6147011/6147047 EXT. # 51

* General notes:

- Civil drawings shall be coordinated with its relative approved Electrical/Mechanical drawings before site execution.
- Future changes and modifications shall be clearly Highlighted/Indicated by revision clouds.

LEGEND:	
A	DULY APPROVED
B	APPROVED WITH COMMENTS
C	APPROVED EXCEPT AS NOTED- RESUBMITT
D	REJECTED
E	INFORMATION

CD UPLOADED
YES
STAMPED
YES

CD UPLOADED	1
STAMPED	2
FAX	

ANWAR
18802

18609

Asad Ur Rahman

Engr.Asad Ur Rahman
PROJECT MANAGER
DESIGN & ENGINEERING
MTMM

RAFIC A. KREIDIE
ENGINEERS & CONTRACTORS
 P.O. Box 14789 Jeddah 21432



KING ABDOULAZIZ UNIVERSITY
 UNIVERSITY MAIN CAMPUS PROJECT
 CONSTRUCTION SUPERVISION CONTRACT
 ZUHAIL FAYEZ PARTNERSHIP CONSULTANTS
 CERTIFICATE OF COMPLIANCE
 DRAWING TRANSMITTAL FORM - TSF-02



System Entry Date Stamp

Contract No: CNCG 502X

Title: General Material Labs, Building-2nd phase

Contractor: Rafic Kreidie Engineers and Contractors

We understand that approval of the drawing(s) submitted herein is only intended to determine general conformance with the intent of the project contract documents. By submitting these drawings for approval, we confirm we have performed all necessary on-site dimensional and building utility requirement coordination, and if approval is granted, will further coordinate the information contained within with all other concerned contractors employed by the University.

Engr Fouad Mahmoud Mohamed Al-Shahrawi
 Name & Signature of Contractor

Transmittal No. ESD-060

Transmittal Date: 12-Nov-15

Subject: SUBSTATION ROOM

Item	Drawing No.	Rev.	Description	Action	Comments
1	E-SD-1202-1	0	SUBSTATION ROOM (1 OF 3)	B	Refer to Electrical notes for corrections on the attached drawings & coordination to P.M.A.
2	E-SD-1202-2	0	SUBSTATION ROOM (2 OF 3)	B	
3	E-SD-1202-3	0	SUBSTATION ROOM (3 OF 3)	B	

The above approval does not relieve the Contractor of any contract obligations, whether for coordination, compliance, or quality with the contract terms and conditions of the contract.

ZEP Project Manager

Date

ACTION CODES:

(A) Approved

(B) Approved As Noted, Resubmittal Not Required

Dec 3-15

(C) Revise and Resubmit

(D) Not Approved

Contractor Receipt:

SPECIAL KINGDOM PROJECTS DEPARTMENT
National Guard Project Division
Thuwal, Jeddah
Tel. (012) 422-4175, Fax. (012) 422-4392

DOCUMENT TRANSMITTAL

Transmittal No.: NGHPD/PH-II/AZM-T-18117

Date: 5-Feb-17

TO: AZMEEL Contracting Co.
Attn: Marwan Zahnan, Proj. Manager

Copy:

- | | | |
|---|--|---|
| <input type="checkbox"/> Administration | <input checked="" type="checkbox"/> Project Engineer | <input checked="" type="checkbox"/> Control (RGC) |
| <input checked="" type="checkbox"/> QA / Material | <input type="checkbox"/> Safety | <input type="checkbox"/> File |

Transmitted herewith are the following:

DOCUMENT TYPE		
<input type="checkbox"/> CALCULATION(S)	<input type="checkbox"/> DRAWING(S)	<input type="checkbox"/> FORM(S)
<input type="checkbox"/> LETTER(S)	<input type="checkbox"/> REPORT(S)	<input checked="" type="checkbox"/> OTHER DOCUMENT(S)

TYPE OF ACTION				
<input checked="" type="checkbox"/> ACTION	<input type="checkbox"/> INFO	<input type="checkbox"/> REVIEW	<input checked="" type="checkbox"/> UPDATE	<input type="checkbox"/> OTHERS

ITEM NO.	QUANTITY	DESCRIPTION
1	1	RTA-NGFCP-C1-M-MS-2013-01 - Heavy Duty Manhole Cover for Water Tank & Sump Box.

REMARKS:

Please see attached RTA-NGFCP-C1-M-MS-2013-01 for information and appropriate action.

Remarks- No Objection As Noted (See attached SAPMT comments sheet)

Transmitted by:



YAS
Salh O. Al-Ghamdi
Salh O. Al-Ghamdi, Project Manager
SKPD/National Guard Project Division

Received by:

Name: _____

Date: _____

Signature: _____

REQUEST FOR TECHNICAL APPROVAL

TO: Mr. Saleh O. Al-Ghandi
Company Representative (SAUDI ARAMCO)
Special Kingdom Project Dept.
National Guard Project Division
Rm. 05, SAP/RT Site Office Bldg.
Thawal, Jeddah, Saudi Arabia

ATTN: Mr. Mohammed G. Al-Shehri
Sr. Project Engineer
CC: Mr. Joseh Mansour
Project Material Specialist
Azrael Contracting Co.
P.O. Box 3043
Dammam, 31471
Saudi Arabia
Tel: 013 826-7260
Fax: 013 826-2196

FROM:

BUILD NO.	25-00704	No. of Copies	3	SUBMITTAL CODE	<input type="checkbox"/> A Architectural
CONTRACT NO.	6600333-21	SPECS REF:		<input type="checkbox"/> C Civil	
PROJECT TITLE	NATIONAL GUARD FAMILY COMPOUND PROJECT	DIV. No.:		<input type="checkbox"/> S Structural	
LOCATION	THAWAL, SAUDI ARABIA	SECTION No.:		<input checked="" type="checkbox"/> M Mechanical	
		DRAWING REFERENCES:		<input type="checkbox"/> E Electrical	
		APPLICABLE SAMSS/INSP:		<input type="checkbox"/> I Instrumentation	
				<input type="checkbox"/> O Others	

New Submittal REFERENCE SUBMITTAL NO. RTA-NGFCP-C1-M-MS-2013-01

Re-submittal DATE 22-Jan-17

REVISION NO. 1 DUMMY P.O. NO. N/A

LEVEL OF INSPECTION NI

BRIEF DESCRIPTION QTY & ISSUE UNIT	SCOM	MFR. NAME / PLANT ID. NO. / ADDRESS	LOCAL VENDOR REF. ADDRESS & I.D. NO.	(FOR SAUDI ARAMCO USE ONLY) REVIEW COMMENTS / APPROVAL / ACTION
Heavy Duty Manhole Cover for Water Tank and Sump Box Items Code: M50S-182-1 & CFSG-743-1	6009001135	NATIONAL CAST IRON PRODUCTS FACTORY	NATIONAL CAST IRON PRODUCTS FACTORY	

NOTE: One Time Approval

RECEIVED

22 JAN 2017

NATIONAL GUARD HOUSING
PROJECT DIVISION

Signature: *[Signature]*

Prepared by:	Reviewed by:	Reviewed by:	Approved by:	Reviewed by:	Approved by:
<i>[Signature]</i> Infrastructure manager Date 22/01/2017	<i>[Signature]</i> Syed Saad Hussain PROCS Date 22/11/2017	<i>[Signature]</i> Mohammed Khan Ahmad Procurement Manager Date 22/01/2017	<i>[Signature]</i> Waseem Zehran Project Manager Date 24/1/2017	<i>[Signature]</i> Mr. Joseh Mansour P&IT Material Specialist Date 11/25/2017	<i>[Signature]</i> Mr. Mohammed G. Al-Shehri Sr. Project Engineer / SAF/RT Date 21/1/17
				<input type="checkbox"/> No Objection	<input checked="" type="checkbox"/> No Objection as noted
				<input type="checkbox"/> Correct & Resubmit	<input type="checkbox"/> Rejected

REQUEST FOR TECHNICAL APPROVAL

SAPMT COMMENT SHEET

PROJECT TITLE: NATIONAL GUARD FAMILY COMPOUND RESIDENTIAL AND INFRASTRUCTURE PROJECT

CONTRACT NUMBER: 6600033421

SUBMITTAL REFERENCE NUMBER: HEAVY DUTY MANHOLE COVER FOR WATER TANK & SUMP BOX# RTA-NGFCP-C1-IM-MS-02013-01 - Jan 23 '17

ITEM	DESCRIPTION / DWG # / DOC #	COMMENTS	INITIATOR'S COMMENTS
1	Heavy duty Manhole Cover for Water Tank & Sump Box	Contractor to ensure that all comment as per compliance sheet shall be applied and followed.	Julius Garcia
2	Heavy duty Manhole Cover for Water Tank & Sump Box	BS Standard as per attached manufacturer submittal shall meet the requirements provided in the specification.	Joey S. Salailia
3	Heavy duty Manhole Cover for Water Tank & Sump Box	Contractor to provide shop drawings and sample that will be applied in this project and to be approved as indicated in the specification	Joey S. Salailia
4	Heavy duty Manhole Cover for Water Tank & Sump Box	Contractor to ensure that all highlighted Catalogue as per the submittal shall be supplied and complied with Project Specifications and requirements.	Joey S. Salailia
5	Heavy duty Manhole Cover for Water Tank & Sump Box	All requirements or deviations in the drawings shall be contractor risk and check by their Technical Team. There shall be no impact in cost or Project Schedule.	Joey S. Salailia
6	Heavy duty Manhole Cover for Water Tank & Sump Box	This submittal is "NO OBJECTION AS NOTED"	Joey S. Salailia 
		COMMENTS CONCURRED BY:	PAGES
		MOHAMMED G. AL-SHEHRI DATE	1 OF 1
		SA, SENIOR PROJ. ENGR.	

Note:
1) This is a supplemental sheet to the RTA form.
2) Comments herein does not relieve the contractor of his responsibilities under the terms of the contract nor authorize him for additional compensation

بسم الله الرحمن الرحيم



المملكة العربية السعودية
وزارة الترخيص

الإدارة العامة للصيانة
صيانة الطرق

الرقم: ٢٧٧٩٨١٠٠

التاريخ: ١١/٥/١٤٣٣ هـ

المرفقات: لم

الموضوع: الموافقة على الخطية بحرف سحب الكوابل مع الحديد الخاصة بعمارة إنتاج شركة المصنع الوطني للتجهيزات الزهر المحدودة

المحترم

المكرم مدير شركة ايطاليا كونسلت

«ص.ب: ٩٩٨ - الرياض: ١١٤٢٦»

السلام عليكم ورحمة الله وبركاته :

إشارة لخطابكم رقم ٤١٠٥٦ وتاريخ ١٤٣٣/٤/١٢ هـ الموجه للإدارة العامة للدراسات والتصميم ومشفوعه خطاب المقاول شركة الخضيف للمقاولات رقم ٧٨٢/٤٥ وتاريخ ٢٠١٣/٢/٢٧ المشار فيه لمشروع استكمال إنارة مداخل المدينة المنورة (١٧) كلم طريق القصيم ٤ كلم ، طريق الهجرة ١٢ كلم ، طريق تبوك ٣٠٠ متر) وطلب المقاول المذكور اعتماد أغطية غرف سحب الكوابل مع الحلوق الخاصة بها وبأبعاد (٩٠٠×٩٠٠) ملم من الحديد الزهر شديد التحمل ، و(٩٠٠×٩٠٠) ملم من الحديد الزهر متوسط التحمل ، و(٦٠٠×٦٠٠) ملم من الحديد الزهر متوسط التحمل من إنتاج شركة المصنع الوطني لمنتجات الزهر المحدودة.

وقد أفادت إدارة الدراسات والتصميم بخطابها رقم ٢٣٠٠٤/٠١ وتاريخ ١٤٣٣/٥/٢ هـ بأنه بدراسة المواصفات المقدمة من المقاول لأغطية غرف السحب المطلوبة مقاس (٩٠٠×٩٠٠) ملم شديدة ومتوسطة التحمل ، ومقاس (٦٠٠×٦٠٠) ملم متوسطة التحمل تبين من خلالها تحقيق مواصفات المشروع وأنه بالإمكان استخدامها في المشروع. نأمل الاطلاع واكمال اللازم ، وقد تم تزويد المقاول بصورة من خطابنا هذا لسرعة تنفيذ الأعمال.

ولكم تحياتنا ...

٥/١/١٧

مدير عام إدارة الصيانة

—

المهندس / محمد بن عبدالله الشهري

ITALCONSULT-SA		IN
Ref: 26221		
Date: 04.04.17	UP	ACT
Branch Manager		
Adminis. Manager		
Design Manager		
Superv. Mgr.		
Relocation. Mgr.		
Note:		

Internal Correspondence | المراسلات الداخلية

EHV ENGINEERING & DESIGN DEPARTMENT

LINES ENGINEERING & DESIGN DIVISION

4th Floor, Platinum Plaza, Al-Andalus St., Jeddah

Our Reference #: 12024201 / 0407 - J / 16
Dated : 22 / 02 / 2016 G
13 / 05 / 1437 H
To : Manager, EHV Projects Department - WOA/SOA
Attention : ENG ABDULLAH AL-MALKI
Project Manager
Tel.#: 012-6537794



Contract # : 4400005832
Project Title : Construction of Underground Cables from 380kV
Gantry-1 to 380kV GIS at Al Adel (ADL) BSP
Subject : Material Specification Cast Iron Cover & Frame for
Manhole/Handhole M/s National Cast Iron Factory

Contractor's Ref. #: CEP/SEC/4400005832/ADLG/DTS-DTS-205 R1

Dated : 07 / 02 / 2016 G

EHV PD Ref. # : 12023001/4400005832/DTS

Dated : 07 / 02 / 2016 G

Date Received @ EHV-EDD/LED: 09 / 02 / 2016 G

STATUS OF THIS SUBMITTAL

- | | | | |
|---------------------------------------|--|----------------------------|----------------------------------|
| <input checked="" type="checkbox"/> A | Acceptable | <input type="checkbox"/> B | Acceptable with Comments |
| <input type="checkbox"/> C | Acceptable, Except as noted (Resubmit) | <input type="checkbox"/> D | Rejected (Resubmit) |
| <input type="checkbox"/> E | Clarification / For Information | <input type="checkbox"/> | See Attached Comments (00 Page) |

If you have any questions, please contact Engineer ABDUL SHAKOOR ALVI on Tel. # 012-263-7053 ext. 108

Regards,

ASA/MAA

Cc: Engr Montes Keskin
CEPCO

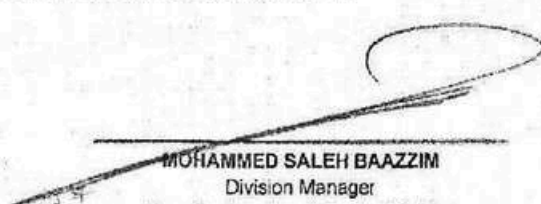
MOHAMMED SALEH BAAZZIM
Division Manager
Lines Engineering & Design Division

Document Submittal Form

Contractor: The Arab contractors (Osman Ahmed Osman & Co.)
P.O. Box 43175, Riyadh 11561, K.S.A."

Contract No. : 4/00/00/0320/001/1/5/19

Project No. : B4 - 13005

Project Name: King Fahad/ Rawda Project (AL Darajah) square

Ref. No.: AC :656

Location: Intersection between Prince Fahad & Rawda street

Date: 01/02/2014

Please check appropriate box:

- | | | |
|--|---|--|
| <input type="checkbox"/> As Built | <input type="checkbox"/> Letter | <input type="checkbox"/> Request for Information (RFI) |
| <input type="checkbox"/> Bill of Quantities | <input type="checkbox"/> Material Sample | <input type="checkbox"/> Schedule |
| <input type="checkbox"/> Certificate | <input type="checkbox"/> Manual | <input type="checkbox"/> Shop Drawing |
| <input type="checkbox"/> Drawing | <input checked="" type="checkbox"/> Pre-qualification | <input type="checkbox"/> Test Reports |
| <input type="checkbox"/> Engineering Calculation | <input type="checkbox"/> Procedure/ Methodology | <input type="checkbox"/> Bank Warranty |
| <input type="checkbox"/> Inspection Request | <input type="checkbox"/> Product Data | <input type="checkbox"/> Others (please specify) |
| <input type="checkbox"/> Job Order | <input type="checkbox"/> Report | |

Purpose:

- For Your Review & Approval As Requested

Subject : Pre-qualification For National Cast Iron Products Factory (NCPF) - For Manhole Covers , Catch Basin Covers &Gutter Drains

Sr. No.	Document Number	Document Name	Rev.	Hard Copy	Soft Copy
		Pre-qualification For National Cast Iron Products Factory (NCPF) - For Manhole Covers , Catch Basin Covers &Gutter Drains	0	3	1

SAPL Review & Approval Status

- Approved (work may proceed)
 Approved as Noted (work may proceed Subject To Incorporation of Comments).
 Revise and Resubmit . work may not proceed .

GIS/CAD Approval

Name :-

sign :-

date:-

Comments :

SEE ATTACHED SUBMITIAL REVIEW COMMENTS

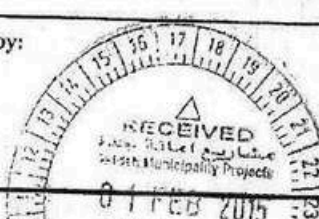
Contractor Project Manager Sign: <i>[Signature]</i> Date: 01/02/2014 For Engineer Submittals Only	Received by: Sign: <i>[Signature]</i> Date:	SAPL Department Sign: <i>[Signature]</i> Date: 03/02/2015
		

Document Submittal Form

Contractor : CIVIL WORKS COMPANY, LTD

Contract No. : 019/005/001/0014/11/00/3 Project No.: Project 53-13011

Name: Maintenance and Improvement of Stormwater, North Jeddah Ref. No. : N-52

Location : Jeddah Municipality Date : 25/12/2013

Please check appropriate box:

- | | | |
|--|--|--|
| <input type="checkbox"/> As Built | <input type="checkbox"/> Letter | <input type="checkbox"/> Request for Information (RFI) |
| <input type="checkbox"/> Bill of Quantities | <input type="checkbox"/> Material Sample | <input type="checkbox"/> Schedule |
| <input type="checkbox"/> Certificate | <input type="checkbox"/> Manual | <input type="checkbox"/> Shop Drawing |
| <input type="checkbox"/> Drawing | <input type="checkbox"/> Pre-qualification | <input type="checkbox"/> Test Reports |
| <input type="checkbox"/> Engineering Calculation | <input type="checkbox"/> Procedure/ Methodology | <input type="checkbox"/> Bank Warranty |
| <input type="checkbox"/> Inspection Request | <input checked="" type="checkbox"/> Product Data | <input type="checkbox"/> Others (please specify) |
| <input type="checkbox"/> Job Order | <input type="checkbox"/> Report | |

Purpose:

- For Your Information For Your Review & Approval As Requested

Subject:

Document Description:

Sr. No	Document No.	Document Name	Rev	Hard copy	Soft Copy
1	N-52	SUPPLIER'S COMPANY PROFILE AND CERTIFICATION	*	1	1

SAPL Review & Approval Status

- Approved (Work may proceed)
- Approved as Noted (Work may proceed subject to Incorporation of Comments)
- Revise and Resubmit (Work may not proceed)

Comments:

① Quality test must comply with Amara Specification

② Material Inspection Result. (MIR) For all material delivered to the site must be approved.

29/12/2013
E.M. HESSE

Contractor Project Manager
Signature
Date: 25/12/2013



SAPL Department Manager
Sign: Larry Bell
Date: 29/12/13

RECEIVED 28 DEC 13 JONATHAN

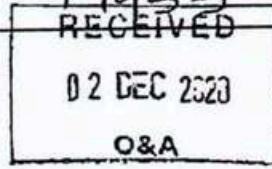

الموضوع: بشأن طلب اعتماد مصنع لتوريد أغطية وأبواب معدنية من مواد
(NCPF) بمشروع إسكان رابع بمنطقة مكة المكرمة

المحترمين / شركة دار الدراسات العمرانية وشركاهم

(الإستشاري المشرف على تنفيذ مشروع إسكان رابع "بنية تحتية" بمنطقة مكة المكرمة)

ص.ب. ٣٦٠٠ الرياض - الرمز البريدي: ١١٤٦١ الفاكس: ٠١١٢٩٣٢٢٤٩٧

السلام عليكم ورحمة الله وبركاته وبعد ،،،،

تهدىكم الإدارة العامة للإشراف على المشاريع أطيب التحايا والتقدير، وإشارة إلى خطابكم رقم
(O&A/7231/HA/644) وتاريخ ١٤٤٢/٠٣/٢٩هـ الوارد للوزارة برقم (٧٩٩٤) وتاريخ ١٤٤٢/٠٢/٢٩هـ، بشأن طلب
اعتماد مصنع لتوريد أغطية وأبواب معدنية من شركة (NCPF) (NATIONAL CAST IRON PRODUCTS)
FACTORY) لمشروع تنفيذ أعمال البنية التحتية لإسكان رابع بمنطقة مكة المكرمة وذلك لمحطة الكهرباء
الفرعية (ESS1).

وبعد دراسة الخطاب ومرفقاته من قبل المختصين، نفيدكم بأنه لا مانع من اعتماد شركة (NATIONAL
CAST IRON PRODUCTS FACTORY) لتوريد أغطية من حديد الزهر أما بالنسبة للأبواب المعدنية فإنه مطلوب
تقديم سابقة الأعمال والكتالوجات الفنية الخاصة بالأبواب المعدنية ، مع ضرورة قيام المقاول بتقديم ما يلي:

١. تقديم شهادة ضمان الشركة الموردة لمدة لا تقل عن عشر سنوات.
٢. تقديم شهادة مطابقة لما يتم توريده من الشركة الموردة.
٣. أن يتم التنفيذ طبقاً لتعليمات الشركة المنتجة.
٤. أن يتم التنفيذ طبقاً للمواصفات العامة وجداول الكميات والمخططات المعتمدة وتعليمات المهندس المشرف.
٥. تقديم شهادة (SASO).

علماً بأن موافقتنا هذه لا تعفى أي من الاستشاري والمقاول من التزاماتهما التعاقدية.

وتقبوا خالص تحياتي وتقديري،،،

مدير عام الإدارة العامة للإشراف على المشاريع

المهندس / ياسر بن نهرم الله الغامدي

بسم الله الرحمن الرحيم



المملكة العربية السعودية
وزارة النقل

الإدارة العامة للصيانة
صيانة الطرق

الرقم: ٢٧٧٤٨ / ١٠

التاريخ: ١١ / ٥ / ١٤٣٤ هـ

المرفقات: لم

الموضوع: الموافقة على أغطية غرف سحب الكوابل مع
الحلقة الخاصة بما من إنتاج شركة المصنع
الوطني لمنتجات الزهر المحدودة

المحترم

المكرم مدير شركة ايपाल كونسولت

«ص.ب: ٩٩٨ - الرياض : ١١٤٢١»

السلام عليكم ورحمة الله وبركاته :

إشارة لخطابكم رقم ٤١٠٥١ وتاريخ ١٢/٤/١٤٣٣هـ الموجه للإدارة العامة للدراسات والتصميم ومشفوعه خطاب المقاول شركة الحضيف للمقاولات رقم ٢٨٢/٤٥ وتاريخ ٢٧/٢/٢٠١٢ المشار فيه لمشروع استكمال إنارة مداخل المدينة المنورة (١٧) كلم "طريق القصيم ٤ كلم ، طريق الهجرة ١٢ كلم ، طريق تبوك ٣٠٠ متر) وطلب المقاول المذكور اعتماد أغطية غرف سحب الكوابل مع الحلوق الخاصة بها وبأبعاد (٩٠٠×٩٠٠) ملم من الحديد الزهر شديد التحمل ، و(٩٠٠×٩٠٠) ملم من الحديد الزهر متوسط التحمل ، و(٦٠٠×٦٠٠) ملم من الحديد الزهر متوسط التحمل من إنتاج شركة المصنع الوطني لمنتجات الزهر المحدودة.

وقد أفادت إدارة الدراسات والتصميم بخطابها رقم ٢٣٠٠٤/٠١ وتاريخ ٢/٥/١٤٣٣هـ بأنه بدراسة المواصفات المقدمة من المقاول لأغطية غرف السحب المطلوبة مقاس (٩٠٠×٩٠٠) ملم شديدة ومتوسطة التحمل ، ومقاس (٦٠٠×٦٠٠) ملم متوسطة التحمل تبين من خلالها تحقيق مواصفات المشروع وأنه بالإمكان استخدامها في المشروع. نأمل الاطلاع وإكمال اللازم ، وقد تم تزويد المقاول بصورة من خطابنا هذا لسرعة تنفيذ الأعمال.

ولكم تحياتنا ...

٥/١١٧

مدير عام إدارة الصيانة

المهندس / محمد بن عبدالله الشهري

ITALCONSULT-SA		IN
Ref:	26221	
Date:	04.04.12	WF ACT
Branch Manager:		
Adminstr. Manager:		
Design Manager:		
Superv. Mat:		
Material. Rate:		
Note:		

EHV ENGINEERING & DESIGN DEPARTMENT

LINES ENGINEERING & DESIGN DIVISION

4th Floor, Platinum Plaza, Al-Andalus St., Jeddah

Our Reference #: 12024201 / 0407 - J / 16
Dated : 22 / 02 / 2016 G
13 / 05 / 1437 H
To : Manager, EHV Projects Department - WOA/SOA
Attention : ENG ABDULLAH AL-MALKI
Project Manager
Tel.#: 012-6537794



Contract # : 4400005832
Project Title : Construction of Underground Cables from 380kV Gantry-1 to 380kV GIS at Al Adel (ADL) BSP
Subject : Material Specification Cast Iron Cover & Frame for Manhole/Handhole M/s National Cast Iron Factory

Contractor's Ref. #: CEP/SEC/4400005832/ADLG/DTS-DTS-205 R1

Dated : 07 / 02 / 2016 G

EHV PD Ref. # : 12023001/4400005832/DTS

Dated : 07 / 02 / 2016 G

Date Received @ EHV-EDD/LED: 09 / 02 / 2016 G

STATUS OF THIS SUBMITTAL

- | | |
|--|--|
| <input checked="" type="checkbox"/> A Acceptable | <input type="checkbox"/> B Acceptable with Comments |
| <input type="checkbox"/> C Acceptable, Except as noted (Resubmit) | <input type="checkbox"/> D Rejected (Resubmit) |
| <input type="checkbox"/> E Clarification / For Information | <input type="checkbox"/> See Attached Comments (00 Page) |

If you have any questions, please contact Engineer ABDUL SHAKOOR ALVI on Tel. # 012-263-7063 ext. 108

Regards,

ASA/MAA

Cc: Engr Mentas Keskin
CEPCO

MOHAMMED SALEH BAAZZIM
Division Manager
Lines Engineering & Design Division

Document Submittal Form

Contractor: The Arab contractors (Osman Ahmed Osman & Co.)
P.O. Box 43175, Riyadh 11561, K.S.A."

Contract No. : 4/00/00/0320/001/1/5/19

Project No. : B4 - 13005

Project Name: King Fahad/ Rawda Project (AL Darajah) square

Ref. No.: AC :656

Location: Intersection between Prince Fahad & Rawda street

Date: 01/02/2014

Please check appropriate box:

- | | | |
|--|---|--|
| <input type="checkbox"/> As Built | <input type="checkbox"/> Letter | <input type="checkbox"/> Request for Information (RFI) |
| <input type="checkbox"/> Bill of Quantities | <input type="checkbox"/> Material Sample | <input type="checkbox"/> Schedule |
| <input type="checkbox"/> Certificate | <input type="checkbox"/> Manual | <input type="checkbox"/> Shop Drawing |
| <input type="checkbox"/> Drawing | <input checked="" type="checkbox"/> Pre-qualification | <input type="checkbox"/> Test Reports |
| <input type="checkbox"/> Engineering Calculation | <input type="checkbox"/> Procedure/ Methodology | <input type="checkbox"/> Bank Warranty |
| <input type="checkbox"/> Inspection Request | <input type="checkbox"/> Product Data | <input type="checkbox"/> Others (please specify) |
| <input type="checkbox"/> Job Order | <input type="checkbox"/> Report | |

Purpose:

- For Your Review & Approval As Requested

Subject : Pre-qualification For National Cast Iron Products Factory (NCPF) - For Manhole Covers , Catch Basin Covers &Gutter Drains

Sr. No.	Document Number	Document Name	Rev.	Hard Copy	Soft Copy
		Pre-qualification For National Cast Iron Products Factory (NCPF) - For Manhole Covers , Catch Basin Covers &Gutter Drains	0	3	1

SAPL Review & Approval Status

- Approved (work may proceed)
 Approved as Noted (work may proceed Subject To Incorporation of Comments) .
 Revise and Resubmit . work may not proceed .

GIS/CAD Approval

Name :-
 sign :-
 date:-

Comments :

SEE ATTACHED SUBMITTAL REVIEW COMMENTS

Contractor: **Project Manager** (عبدالله بن عثمان احمد)
 Sign: *[Signature]*
 Date: 01/02/2014
 The Arab Contractors
 (OSMAN AHMED OSMAN & Co.)
 For Engineer Submittals Only

Received by:

Sign: *[Signature]*
 Date:

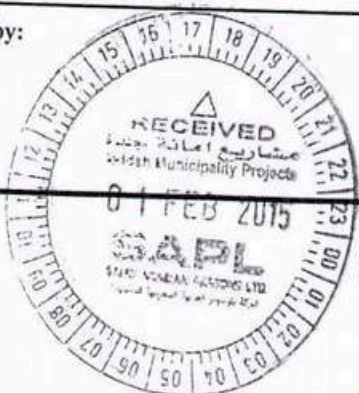

SAPL Department

Sign: *[Signature]*
 Date: 03/02/2015

[Signature] MCG
 03/02/15

[Signature] Babbar
 2-2-2015

بِسْمِ اللَّهِ الرَّحْمَنِ الرَّحِيمِ



المملكة العربية السعودية
وزارة الشؤون البلدية والقروية
أمانة محافظة الطائف

الرقم: ١٤٤٠/١٨١٢٣
التاريخ: ١٤٤٠/١٨/٢٤
الرقم: ١٤٤٠/١٨١٢٣

وكالة المشاريع
الإدارة العامة للمراسم والإشراف

السادة / شركة المصنع الوطني لمنتجات الزهر المحدودة

جدة ص ب ٥٠٧٥٢ الرمز البريدي ٢١٥٢٢ فاكس ٠١٢٦٢٣٧٥٨٠٠

السلام عليكم ورحمة الله وبركاته:

إشارة إلى الخطاب الوارد إلينا بالرقم ٢٤٧٠٢ وتاريخ ١٤٤٠/٠٧/٢٤ هـ بخصوص اعتماد اغطية المصارف الصحية السطحية لمشاريع درء اخطار السيول وتصريف الأمطار (تصريف حي القمرية) .

وبعد زيارة المصنع المذكور من قبلنا والاطلاع على المواد المنتجة وعمل الاختبارات اللازمة عليها للتأكد من مطابقتها للمواصفات الفنية .

عليه نفيدكم بأنه لا مانع لدينا من اعتماد مصنعكم لتوريد اغطية المصارف السطحية لمشاريع درء اخطار السيول وتصريف الأمطار (تصريف حي القمرية) .

والسلام عليكم ورحمة الله وبركاته ، ، ،

وكيل الأمين للمشاريع

مشعل مطلق القثامي

Document Submittal Form

Contractor : CIVIL WORKS COMPANY, LTD

Contract No. : 019/005/001/0014/11/00/3 **Project No.: Project** S3-13011

Name: Maintenance and Improvement of Stormwater, North Jeddah **Ref. No. :** N-52

Location : Jeddah Municipality **Date :** 25/12/2013

Please check appropriate box:

<input type="checkbox"/> As Built	<input type="checkbox"/> Letter	<input type="checkbox"/> Request for Information (RFI)
<input type="checkbox"/> Bill of Quantities	<input type="checkbox"/> Material Sample	<input type="checkbox"/> Schedule
<input type="checkbox"/> Certificate	<input type="checkbox"/> Manual	<input type="checkbox"/> Shop Drawing
<input type="checkbox"/> Drawing	<input type="checkbox"/> Pre-qualification	<input type="checkbox"/> Test Reports
<input type="checkbox"/> Engineering Calculation	<input type="checkbox"/> Procedure/ Methodology	<input type="checkbox"/> Bank Warranty
<input type="checkbox"/> Inspection Request	<input checked="" type="checkbox"/> Product Data	<input type="checkbox"/> Others (please specify)
<input type="checkbox"/> Job Order	<input type="checkbox"/> Report	

Purpose:

For Your Information For Your Review & Approval As Requested

Subject:

Document Description:

Sr. No	Document No.	Document Name	Rev	Hard copy	Soft Copy
1	N-52	SUPPLIER'S COMPANY PROFILE AND CERTIFICATION		1	1

SAPL Review & Approval Status

Approved (Work may proceed)

Approved as Noted (Work may proceed subject to Incorporation of Comments)

Revise and Resubmit (Work may not proceed)

Comments:

① Quality test must comply with Amana Specification

② Material Inspection Result. (MIR) for all material delivered to the site must be approved.

29/12/2013
Eng. H. ESSA

Contractor Project Manager

Sign: *[Signature]*

Date: 25/12/2013







SAPL Department Manager

Sign: *[Signature]*

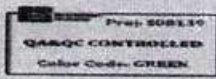
Date: 29/12/13

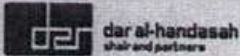
RECD USELL 26 DEC 13 JONATHAN

Project Title: Al Haramain High Speed Rail Phase-1 package-2 Project No. S08139		Employer: 	Submittal No. P1P2-S1-SAM-M-2096-R00
Engineer: 	Contractor: 		Date: 08-08-2017

SUBMITTAL FOR APPROVAL OF MATERIALS

REF:

1. MATERIAL DESCRIPTION (One item only on this form):

Ductile Iron Gully Cover & Linear Drainage (Samples at Site -See attached sample photos)

Area of Application: External area

Drawing Ref:

B.O.Q Ref No. : Bill No. 2D -Section A+C

Specification Ref: HHR-P1P2-S1-ME-SP-0003-01

Standards:

2. Manufacturer / Supplier:

Company Name: National Cast Iron Factory

Address: P.O.Box : 42459, Jeddah 21541, K.S.A.

Local Agent:

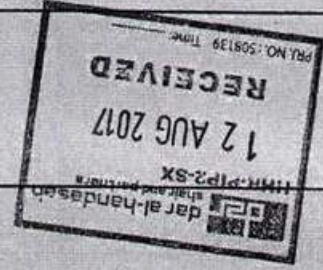

3. Delivery:

Country of Origin:

Locally Manufactured Overseas

Delivery: Ex-works/ Total Duration []
 Estimated Time of Arrival on Site []
 Program: Date Material Required on Site []
 Latest Date for Order []

We certify that the above submitted items that have been reviewed in detail and are correct and in strict conformity with the contract drawings and specifications except as otherwise stated; the submitted items in conformity with the above and deliver same timely. also that the material sources indicated above have been reviewed in detail and that they will supply.

Submitted by: Badr Ghazal

Signature: 

ENGINEER'S REPRESENTATIVE'S COMMENTS



Copy with manufacturer's recommendation and written instructions during last Mtg.

ACTION TAKEN:

- Approved
- Approved as Noted
- Revise and resubmit
- Rejected
- Sample Required
- Test Required
- Additional Information Required
- Manufacturer's Guarantee Required

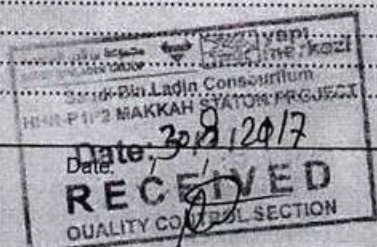
Signature

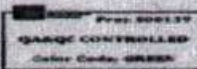
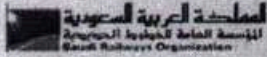
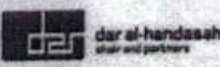

Project Title: Al Haramain High Speed Rail Phase-1 package-2 Project No. S08139		Employer: 	Submittal No. P1P2-S1-SAM-S-2060
Engineer: 	Contractor: 	Date:- 04-05-2017	

SUBMITTAL FOR APPROVAL OF MATERIALS

REF:

1.MATERIAL DESCRIPTION (One item only on this form):
 Manhole Covers (Samples at Site -See attached sample photo).
 Area of Application: External area
 Drawing Ref: _____ B.O.Q Ref No. : Bill No. 2D -Section A+C
 Specification Ref: HHR-P1P2-S1-ME-SP-0003-01 Standards: _____

2.Manufacturer / Supplier:
 Company Name: National Cast Iron Factory
 Address: P.O.Box : 42459, Jeddah 21541, K.S.A.
 Local Agent: _____

3.Delivery:
 Country of Origin: _____
 Locally Manufactured Overseas
 Delivery: Ex-works/ Total Duration []
 Estimated Time of Arrival on Site []
 Program: Date Material Required on Site []
 Latest Date for Order []



We certify that the above submitted items that have been reviewed in detail and are correct and in strict conformity with the contract drawings and specifications except as otherwise stated; the submitted items in conformity with the above and deliver same timely, also that the material sources indicated above have been reviewed in detail and that they will supply.

Submitted by: Badr Ghazal Signature: 

ENGINEER'S REPRESENTATIVE'S COMMENTS

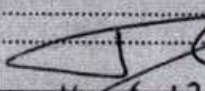
.....
 only ductile iron manhole covers are accepted
 covers shall have slope / E-grained of EN standard joint D max class
 Signature:  Date: / /

ACTION TAKEN:

Approved
 Approved as Noted
 Revise and resubmit
 Rejected
 Sample Required
 Test Required
 Additional Information Required
 Manufacturer's Guarantee Required

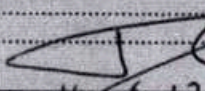
Signature:  Date: / /

Approval shall not relieve contractor of his liabilities under the contract or constitute authorization of any change to contract documents.

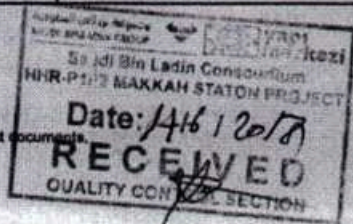

01:

الجمهورية العربية السورية
مجلس الوزراء
مديرية المواصلات
إدارة سكك الحديد

<p>Project Title: Al Haramain High Speed Rail Phase-1 part 2</p> <p>Engineer: <i>[Signature]</i></p>			<p>3</p>
--	--	--	----------

<p>الجمهورية العربية السورية مجلس الوزراء مديرية المواصلات إدارة سكك الحديد</p>		
---	--	--

مديرية المواصلات
إدارة سكك الحديد
مكتب الدراسات والبحوث
الهندسة المدنية
الاسم: *[Name]*
الرقم: *[Number]*



RECEIVED

مديرية المواصلات
إدارة سكك الحديد
مكتب الدراسات والبحوث
الهندسة المدنية
الاسم: *[Name]*
الرقم: *[Number]*

	<p>pp ppr ev keje</p>
--	-----------------------------------

7/10/1479

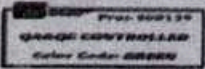
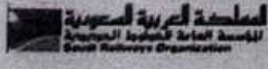
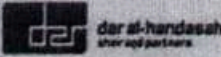
Date:

Project Title: Al Haramain High Speed Rail Phase-1 package-2 Project No. S08139		Employer: 	Submittal No. P1P2-S1-SAM-M-2080-R00
Engineer: 	Contractor:  SAUDI BIN LADEN CONSORTIUM FOR - P1P2		Date: 04-07-2017

SUBMITTAL FOR APPROVAL OF MATERIALS

REF:

1. MATERIAL DESCRIPTION (One item only on this form):

Cast Iron Manhole Cover & Recessed Type Cover (Samples at Site -See attached sample photos)

Area of Application: External area

Drawing Ref:

B.O.Q Ref No. : Bill No. 2D -Section A+C

Specification Ref: HHR-P1P2-S1-ME-SP-0003-01

Standards:

2. Manufacturer / Supplier:

Company Name: National Cast Iron Factory

Address: P.O.Box : 42459, Jeddah 21541, K.S.A.

Local Agent:

3. Delivery:

Country of Origin:

Locally Manufactured

Overseas

Delivery: Ex-works/ Total Duration []

Estimated Time of Arrival on Site []

Program: Date Material Required on Site []

Latest Date for Order []



We certify that the above submitted items that have been reviewed in detail and are correct and in strict conformity with the contract drawings and specifications except as otherwise stated; the submitted items in conformity with the above and deliver same timely. also that the material sources indicated above have been reviewed in detail and that they will supply.

Submitted by: Badr Ghazal

Signature: 

ENGINEER'S REPRESENTATIVE'S COMMENTS

1- Provide the name of the service on this cover of the manhole as per local authority terminology.
2- All manhole covers shall be Heavy Duty Ductile iron except recessed type at land side pavement are shall be cast iron.
3- Provide stamp of EN standard at cover

- ACTION TAKEN:**
- Approved
 - Approved as Noted
 - Revise and resubmit
 - Rejected
 - Sample Required
 - Test Required
 - Additional Information Required
 - Manufacturer's Guarantee Required

Signature

Date: 1 / 1

22 / 7 / 17

Approval shall not relieve contractor of his liabilities under the contract or constitute authorization of any change to contract documents.

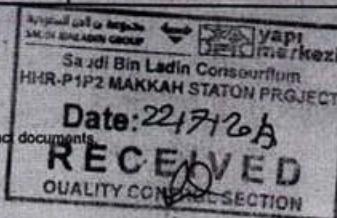



أمانة جدة
Jeddah Municipality



Louis Berger



SUBMITTAL FORM

Submittal No.: JSW-CP-SNET- PRQ-CI-0010

Rev. No.:

PROJECT	CONTRACT	OWNER	CONTRACTOR
Jeddah Stormwater Drainage (JSWD)	SUBNET D006/UP03	Jeddah Municipality	Civil & Electrical Projects Contracting Company.

Subject: Pre-Qualification for NCPF CO. LTD (COVER FOR MANHOLE, CATCH BASIN & PRD)

Specs. Code & Ref.:	BOQ Code Ref.	Drawing No.:	Date Received: _____
			Date Returned: _____

Sub-Contractor

Name: _____ Phone: _____
Address: _____

Manufacturer
Name: NATIONAL CAST IRON PRODUCTS FACTORY
Address: P.O BOX 50753, JEDDAH 21533
Phone: 00966-12 6370496

Supplier / Agent
Name: _____
Address: _____
Phone: _____

Information Submitted and Attached:

- | | |
|---|---|
| <input type="checkbox"/> Certificates | <input type="checkbox"/> Operation & Maintenance Manual |
| <input type="checkbox"/> Technical Brochure | <input type="checkbox"/> Spare Parts List |
| <input type="checkbox"/> Manufacturer's Data & Specs. | <input type="checkbox"/> As-Built Drawings |
| <input type="checkbox"/> Shop Drawings | <input type="checkbox"/> Warranty |
| <input type="checkbox"/> Samples | <input type="checkbox"/> Others (specify): _____ |



Contractor Comments: For Review and Approval

See Attachment

Note: This review does not relieve the Contractor of his responsibilities under the terms of the Contract nor authorizes additional compensation.

Name: **Mr. Yousef Mahmoud Shaeira**

Signature: _____
Date: 6/2/2019

See Attachment

Consultant Comments:

- Status:**
- A: Approved
 - B: Temporary Approved
 - C: Revise and Resubmit
 - D: Rejected
 - I: For Information

- Discipline**
- Geotechnical
 - Architectural
 - Civil / Structural
 - Mechanical
 - Electrical
 - HSE

Louis Berger Engineer
Name: **Hamed Alkhatas**
Signature: _____
Date: 24 Feb 2019

Louis Berger Project Director
Name: **DAVE HUGHES**
Signature: _____
Date: 25/02/19

SPECIAL KINGDOM PROJECTS DEPARTMENT
National Guard Project Division
Thuwal, Jeddah
Tel. (012) 422-4175, Fax. (012) 422-4392

DOCUMENT TRANSMITTAL

Transmittal No.: NGHPD/PH-II/AZM-T-181/17

Date: 5-Feb-17

TO: AZMEEL Contracting Co.
Attn: Marwan Zahnan, Proj. Manager

Copy:

- | | | |
|---|--|---|
| <input type="checkbox"/> Administration | <input checked="" type="checkbox"/> Project Engineer | <input checked="" type="checkbox"/> Control (RGC) |
| <input checked="" type="checkbox"/> QA / Material | <input type="checkbox"/> Safety | <input type="checkbox"/> File |

Transmitted herewith are the following:

DOCUMENT TYPE		
<input type="checkbox"/> CALCULATION(S)	<input type="checkbox"/> DRAWING(S)	<input type="checkbox"/> FORM(S)
<input type="checkbox"/> LETTER(S)	<input type="checkbox"/> REPORT(S)	<input checked="" type="checkbox"/> OTHER DOCUMENT(S)

TYPE OF ACTION				
<input checked="" type="checkbox"/> ACTION	<input type="checkbox"/> INFO	<input type="checkbox"/> REVIEW	<input checked="" type="checkbox"/> UPDATE	<input type="checkbox"/> OTHERS

ITEM NO.	QUANTITY	DESCRIPTION
1	1	RTA-NGFCP-C1-M-MS-2013-01 - Heavy Duty Manhole Cover for Water Tank & Sump Box.

REMARKS:

Please see attached RTA-NGFCP-C1-M-MS-2013-01 for Information and appropriate action.

Remarks- **No Objection As Noted (See attached SAPMT comments sheet)**



Transmitted by:

YAS
Saleh O. Al-Ghamdi
Saleh O. Al-Ghamdi, Project Manager
SKPD/National Guard Project Division

Received by:

Name: _____
Signature: _____

Date: _____

REQUEST FOR TECHNICAL APPROVAL

SAPMT COMMENT SHEET

PROJECT TITLE: NATIONAL GUARD FAMILY COMPOUND RESIDENTIAL AND INFRASTRUCTURE PROJECT

CONTRACT NUMBER: 6600033421

SUBMITTAL REFERENCE NUMBER: HEAVY DUTY MANHOLE COVER FOR WATER TANK & SUMP BOX# RTA-NGFCP-C1-M-MS-02013-01 - Jan 23 '17

ITEM	DESCRIPTION / DWG # / DOC #	COMMENTS	INITIATOR'S COMMENTS
1	Heavy duty Manhole Cover for Water Tank & Sump Box	Contractor to ensure that all comment as per compliance sheet shall be applied and followed.	Julius Garcia
2	Heavy duty Manhole Cover for Water Tank & Sump Box	BS Standard as per attached manufacturer submittal shall meet the requirements provided in the specification.	Joey S. Salalila
3	Heavy duty Manhole Cover for Water Tank & Sump Box	Contractor to provide shop drawings and sample that will be applied in this project and to be approved as indicated in the specification	Joey S. Salalila
4	Heavy duty Manhole Cover for Water Tank & Sump Box	Contractor to ensure that all highlighted Catalogue as per the submittal shall be supplied and complied with Project Specifications and requirements.	Joey S. Salalila
5	Heavy duty Manhole Cover for Water Tank & Sump Box	All requirements or deviations in the drawings shall be contractor risk and check by their Technical Team. There shall be no impact in cost or Project Schedule.	Joey S. Salalila
6	Heavy duty Manhole Cover for Water Tank & Sump Box	This submittal is "NO OBJECTION AS NOTED"	Joey S. Salalila 

Note:

- 1) This is a supplemental sheet to the RTA form.
- 2) Comments herein does not relieve the contractor of his responsibilities under the terms of the contract nor authorize him for additional compensation

COMMENTS CONCURED BY:	PAGES
MOHAMMED G. AL-SHEHRI DATE	1 OF 1
SA, SENIOR PROJ. ENGR.	

SUPPLIERS PRE-QUALIFICATION SUBMITTAL REVIEW FORM

Discipline	Contractor :	Civil Works Company Limited (CWC)		
BT-Bridges & Tunnel	Contract No:	019/005/2/001/0014/10/00/3	Project No.	S3-18002
H-Hydraulics	X	Project:	Maintenance and Improvement of Storm Water and Networks Reduce the level of Groundwater in south and East Jeddah Sou	
RH-Road & Highways	Submittal No:	DT-49	Status:	Revise & Resubmit
BF- Building & Facilities	Please see below MME comments. If in red color, contractor must rectify all necessary items in the revised/next submission for final review.			
ME-Mechanical & Electrical	These documents have been reviewed for general conformance with the contract. Such review does not relieve the contractor of his responsibilities under the authorized terms and condition of the contract.			
LG-Landscape & Gardens				

No.	Item Description	MME Comments	Contractor Response
1	Company Profile	Provided, acceptable	
2	List of Materials to be Supplied	Not Provided as per contract material BOQ Item description D1 either Cast iron	
3	Organizational Chart	Provided, acceptable	
4	Commercial Documents/Government Registrations		
4.1	Company Registration	Provided and validity period until 08/11/1439(H)	
4.2	Industrial License	Provided and validity period until 08/08/1440(H)	
4.3	Zakat Certificate	Provided and validity period until 25/08/1440(H)	
4.4	Chamber of Commerce Certificate	Provided and validity period until 08/11/1439(H)	
4.5	GOSI	Provided and validity period until 01/10/1439(H)	
5	ISO or other Quality Certifications: 9001-2008, 14001	Not Provided	Provided and validity until
6	SASO Certification	Not Provided	
7	List of Machineries/Equipment (supporting with valid Third-Party Calibration Certificates)	Not Provided	
8	Vendor Previous Approvals	Provided, acceptable	
9	Completed Project References	Provided, acceptable	
10	Others (As deemed necessary)	This is only the Pre-qualification of contractor's proposed supplier NCPF Products Contractor's should submit product/material submittal separately (along with relevant test results shall have original stamp NCPF, if applicable) for FINAL APPROVAL	

- Remarks:**
- Contractor shall submit material sample of relevant products (along with all relevant documents and test results must have NCPF . original stamp) for Final review & approval.
 - Material/Product from the supplier or manufacturer shall be used only after approval of the relevant material/product from the Engineer.

Checked/Reviewed By: Muhammed Salem Mohammed Majid Tariq Hakim
 Title: Hydraulics Engineer QA/QC Engineer O&M Manager
 Signature: _____
 Date: _____
 27/5/18



ترخيص صناعي وطني

رقم: (٢٣٩٢) بتاريخ : ٠٨/٠٩/١٤٣٧هـ
تجديد للترخيص رقم: ٦٨ بتاريخ: ٠٣/٠٥/١٣٩٥هـ

رمز المنشأة ١٠٠١٢١

السجل التجاري للمنشأة ٤٠٣٠١٢٣٥٥

فاكس ٦٣٧٥٨٠٠

الرمز البريدي ٢١٥٢٣

إسم المنشأة المصنع الوطني لمنتجات الزهر
موقع المنشأة جدة (N21.43043970 - E39.22204971)
ملكية المنشأة شركة المصنع الوطني لمنتجات الزهر المحدوده (رقم السجل التجاري: ٤٠٣٠١٢٣٥٥ / الجنسية: السعودية)
المدينة جدة صندوق البريد

هاتف ٦٣٧٠٤٩٦

وصف المنتج	رمز المنتج	الوحدة	الطاقة الإنتاجية	وصف المنتج	رمز المنتج	الوحدة
"محابس"	مسيوكات حديد زهر "موسير - أكواخ - توصيلات - محابس"	طن	٥٠	مسيوكات زهر مرز	٧٢٠٦١٠٠٠	طن
	مستلزمات التلييب الكتائيل (أكواخ ، وصلات)	طن	٥٠	مسيوكات زهر رمادي (غطية غرف التقطير وبيارات وصرف مياه الأمطار)	٧٢١٦٥٠٠٠	طن
	مسيوكات الملبوم	طن	١٠٠	مسيوكات: نحاسية من الفردة	٧٤٠٣١٣٠٠	طن

النشاط الصناعي سبك الحديد والصلب (رمز النشاط: ٢٤٣١)

وزير الطاقة والصناعة والثروة المعدنية

خالد بن عبدالعزيز الفالح



عدد العمالة ٨٠ (ثمانون) فردا.
اجمالي التمويل ١٥,٥ (خمسة عشر و خمسة من عشرة) مليون ريال.

ملاحظة هامة: التعليمات خلف الترخيص مضممة له

تنتهي صلاحية هذا القرار بتاريخ ٠٨/٠٨/١٤٤٠هـ

QUALITY CERTIFICATE
RAJHI STEEL INDUSTRIAL CO .LTD

P.O.Box: 40707 - Riyadh 11511
Kingdom of Saudi Arabia
U : 920011222



شهادة الجودة
شركة الراجحي للصناعات الحديدية المحدودة

ص.ب. ٤٠٧٠٧ - الرياض ١١٥١١
المملكة العربية السعودية
ت: ٩٢٠٠١١٢٢٢

Pages 1-2

Customer Name/Address :	إسم وعنوان العميل:	Shipping Address :	عنوان الشحن :	Certificate No :	37907	رقم شهادة الاختبار:
				Customer No :		رقم العميل:
				Sales Order No :		رقم أمر البيع:
				Customer Order No :		رقم أمر الشراء:
				Delivery Note No :		رقم أمر التحميل:
				Date Of Issue :	01-Nov-2021	تاريخ الإصدار:

وصف البضاعة Product Description		رقم الصبة Heat/Cast No.	Mechanical Properties الخصائص الميكانيكية							Chemical Composition (%) التركيب الكيميائي						الوزن (طن) Weight (MT)	عدد القضبان لكل ربطة No. of bars per bundle	عدد الربطات No. of Bundles
المقاس Size	المواصفة Standard		وزن المتر Nominal Wt. (Kg/m)	مقاومة الخضوع Yield Strength (N/mm2)	مقاومة الشد Tensile Strength (N/mm2)	نسبة الاستطالة Elongation %	مدلول مقياس الطول Gauge Length (mm)	مساحة المقطع Cross Section Area (mm2)	اختبار التي Bend Test	كربون C	سيليكون Si	منغنيز Mn	فسفور P	كبريت S	نيتروجين N			
10 mm	SASO ASTM A615M GR 420	H 78838 R	0.617	566	656	11.0	200	79	OK	0.21	0.136	0.62	0.009	0.032	0.0090	-	270	-
12 mm	SASO ASTM A615M GR 420	H 91541 R	0.888	578	682	12.0	200	113	OK	0.21	0.161	0.60	0.020	0.024	0.0109	-	188	-
14 mm	SASO ASTM A615M GR 420	L 32704 S92	1.208	573	672	12.0	200	154	OK	0.21	0.235	0.72	0.018	0.032	0.0109	-	138	-
16 mm	SASO ASTM A615M GR 420	H 89850 R	1.578	567	661	12.0	200	201	OK	0.20	0.169	0.61	0.005	0.021	0.0118	-	106	-
18 mm	SASO ASTM A615M GR 420	H 86781 R	1.998	553	647	11.0	200	255	OK	0.20	0.192	0.70	0.004	0.028	0.0114	-	84	-
20 mm	SASO ASTM A615M GR 420	H 89255 R	2.466	576	680	12.0	200	314	OK	0.21	0.238	0.86	0.007	0.029	0.0116	-	68	-
25 mm		H 90944 R	3.853	594	692	12.5	200	491	OK	0.20	0.211	0.78	0.007	0.024	0.0105	-	44	-

THIS IS AN ELECTRONICALLY GENERATED CERTIFICATE, DOES NOT REQUIRE SIGNATURE OR STAMP.

5578

Rev.no:00



000 / الج 100

Bar mark as per Al Rajhi standards
العلامة المميزة لقبضان حديد الراجحي

Rev date: 12/04/2018
QC 015

QUALITY CERTIFICATE
RAJHI STEEL INDUSTRIAL CO .LTD

P.O.Box: 40707 - Riyadh 11511
Kingdom of Saudi Arabia
U : 920011222



شهادة الجودة
شركة الراجحي للصناعات الحديدية المحدودة

ص.ب. ٤٠٧٠٧ - الرياض ١١٥١١
المملكة العربية السعودية
ت: ٩٢٠٠١١٢٢٢

Pages 2-2

Customer Name/Address :	إسم وعنوان العميل :	Shipping Address :	عنوان الشحن :	Certificate No :	37907	رقم شهادة الاختبار :
				Customer No :		رقم العميل :
				Sales Order No :		رقم أمر البيع :
				Customer Order No :		رقم أمر الشراء :
				Delivery Note No :		رقم أمر التحميل :
				Date Of Issue :	01-Nov-2021	تاريخ الإصدار :

وصف البضاعة Product Description		Mechanical Properties الخصائص الميكانيكية								Chemical Composition (%) التركيب الكيميائي						الوزن (طن) Weight (MT)	عدد القضبان لكل ربطة No. of bars per bundle	عدد الربطات No. of Bundles
المقاس Size	المواصفة Standard	رقم الصبة Heat/Cast No.	وزن المتر Nominal Wt. (Kg/m)	مقاومة الخضوع Yield Strength (N/mm2)	مقاومة التشد Tensile Strength (N/mm2)	نسبة الاستطالة Elongation %	مدلول مقياس الطول Gauge Length (mm)	مساحة المقطع Cross Section Area (mm2)	الختبار الثني BendTest	كربون C	سيليكون Si	منغنيز Mn	فسفور P	كبريت S	نيتروجين N			
32 mm	SASO ASTM A615M GR 420	H 88260 R	6.313	573	683	14.5	200	805	OK	0.20	0.225	0.83	0.004	0.022	0.0106	-	26	-
40 mm	SASO ASTM A615M GR 420	L28004 U75	9.865	545	656	11.0	200	1257	OK	0.19	0.186	0.60	0.018	0.003	0.0108	-	17	-

THIS IS AN ELECTRONICALLY GENERATED CERTIFICATE, DOES NOT REQUIRE SIGNATURE OR STAMP.

5578

Rev.no:00



000 / الج 100

Bar mark as per Al Rajhi standards
العلامة المميزة لقبضان حديد الراجحي

Rev date: 12/04/2018
QC 015

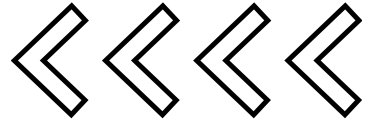

تواصل معنا



المطور المعتمد
للمقاولات



+966-500118785



WWW.CCD.COM.SA



N@CCD.SA



KSA, JEDDAH 23523



Thank You!

